

**DINA**

---



**User manual and  
installation  
instructions**

**CE**

---

 **BIASI**

---

Congratulations on choosing this product.

Your modulating boiler is electronically adjusted and ignited.

- It is highly efficient
- It has a sealed chamber

Unlike traditional boilers, your condensing boiler makes it possible to recover energy by condensing the water vapour contained in the flue gas. This means that, with equal heat production, it **consumes less gas**, and the flue gas contains **fewer substances that are harmful** to the environment.

The materials used and the control systems offer safety, high levels of comfort and energy savings so you can appreciate the maximum advantages of autonomous heating.



## GENERAL WARNINGS



- ✓ This manual contains important information aimed at:
  - Users (section 1);
  - Installers (section 2);
  - Maintenance technicians (section 3).
- ✓ Users must read the instructions in the relevant section carefully (section 1).
- ✓ Users must only perform work on the appliance where explicitly stated in the relevant section.
- ✓ Improper installation or assembly of the appliance and/or components, accessories, kits and devices supplied with the product may cause unforeseeable problems for people, animals or property. Please read the instructions provided with the product for information on how to install the product correctly.
- ✓ This instruction manual contains technical product installation information. As regards other topics related to product installation (e.g. occupational safety, accident prevention and protecting the environment), you must observe the legislation in force and codes of practice.
- ✓ Maintenance must be performed by qualified technicians e.g. at an authorised service centre, so as to guarantee a professional service.
- ✓ Any errors occurring during installation, or while using or servicing the appliance, caused by a failure to observe the technical legislation and regulations in force or the instructions in this manual (or otherwise provided by the manufacturer) will exclude the manufacturer from all contractual and non-contractual liability for any damage caused and will void the appliance warranty.

---

## IMPORTANT

- ✓ **The manual** must be read carefully to ensure rational and safe use of the boiler. It must be stored with care as it may be necessary to consult it in the future. If the unit is transferred to another owner, the manual must accompany the boiler.
- ✓ **The initial switch-on** must be carried out by an Authorised Service Centre; the validity of the warranty starts from the date the product is purchased.
- ✓ **The manufacturer** declines all liability for translations of this manual from which incorrect interpretations may result. It cannot be considered responsible for failure to observe the instructions contained in this manual or the consequences of any actions that have not been specifically described.

## DURING INSTALLATION

- ✓ After removing the packaging, make sure that the appliance **is not damaged**. If damaged **do not install or start up** the appliance as it may be dangerous. Contact your retailer or the nearest authorised service centre.
- ✓ **Installation** must be carried out by qualified professionals who are responsible for compliance with all applicable national and local laws and standards:
  - the suitability of the installation site;
  - the robustness of the wall intended for installation;
  - the distance of the appliance from walls and surrounding objects;
  - correct hook-up to the gas system;
  - correct and safe set-up of the of air supply and combustion products evacuation system;
  - correct hook-up to the electrical power supply and earth circuit;
  - compliance with the technical specifications.
- ✓ **The boiler** is used to heat water to a temperature that is lower than boiling point, and must be connected to a heating system and/or a domestic hot water distribution network that is compatible with its performance and power.

The boiler must be supplied with **Methane gas (G20) or LPG (Propane G31). Group H and/or group E** combustible gases and **natural gas and hydrogen mixtures** up to 20% by volume may also be used.

The condensate discharge must be connected to the residential condensate outlet duct and it must be possible to inspect it.

The boiler must only be used for the purpose for which it was designed. Furthermore:

  - It must not be exposed to atmospheric agents.
  - The appliance can be used by children no younger than 8 years old, by people with physical, sensory or cognitive disabilities, and by people lacking experience or the necessary knowledge, provided that they are supervised or have received instructions on the safe use of the appliance and understand the inherent risks. Do not let children play with the appliance. Do not allow unsupervised children to perform user maintenance and cleaning.
  - Prevent incorrect use of the boiler.
  - Avoid making adjustments to the sealed devices.
  - Avoid contact with hot parts during operation.

---

## DURING USE

- ✓ **It is prohibited and dangerous** to obstruct, even partially, the air intakes for the ventilation of the room where the boiler is installed.
- ✓ **Repairs** must only be carried out by authorised service centres using original spare parts. Therefore, in the case of a problem, deactivate the boiler only (see instructions).
- ✓ **If you smell gas:**
  - Do not turn on electric switches, the telephone or any other object that could create sparks.
  - Immediately open up the doors and windows to create an air current that cleans the room.
  - Close the gas valves.
  - Request the intervention of professionally qualified personnel.
- ✓ **Before starting the boiler**, have a qualified professional check that the gas supply system:
  - Is perfectly sealed.
  - is the right size for the required flow rate to the boiler.
  - is equipped with the safety and control devices required by current standards;
  - Make sure that the installer has connected the safety valve drain to a outlet funnel.  
The manufacturer is not responsible for damage caused by the water released when the safety valve opens, if it is not correctly connected to a drainage system.
  - Make sure that the installer has connected the condensate siphon drain to a specific outlet funnel, which must be implemented in order to avoid the condensate freezing and ensure it is correctly drained.
- ✓ **Near the boiler:**
  - there must be a multiway switch to isolate the appliance from the electric power supply;
  - a gas shut-off valve to interrupt the flow of fuel.
- ✓ **Do not touch the unit** with wet or damp body parts and/or in bare feet.
- ✓ **If performing structural work or maintenance** near the flue gas ducts and/or the flue gas exhaust devices or their accessories, turn off the unit and, when the work is complete, have a qualified technician check the efficiency.



**DANGER:** Instructions marked with this symbol must be observed to prevent mechanical or generic accidents (e.g. injuries or bruises).



**DANGER:** Instructions marked with this symbol must be observed to avoid electrical accidents (electrocution).



**DANGER:** Instructions marked with this symbol must be observed to avoid the risk of fire or explosions.



**DANGER:** Instructions marked with this symbol must be observed to avoid heat-related accidents (burns).



**WARNING:** Instructions marked with this symbol must be observed to avoid malfunctions and/or material damage to the unit or other items.



**WARNING:** Instructions marked with this symbol contain important information that must be read carefully.



**WARNING:** Risk of cutting / stabbing. Protective gloves must be worn.

**Appliance category:** II2H3P (gas G20 20 mbar, G31 37 mbar)

**Destination country:** GB

This unit is compliant with the following European Directives:

- Regulation (EU) 2016/426 on appliances burning gaseous fuels
- Boiler Efficiency Directive: Article 7(2) and Annex III of 92/42/EEC
- Electromagnetic Compatibility Directive 2014/30/EU
- Low Voltage Directive 2014/35/EU
- Directive 2009/125/EC Ecodesign requirements of energy-related products
- Regulation (EU) 2017/1369 Energy labelling
- Delegated regulation (EU) no. 811/2013
- Delegated regulation (EU) no. 813/2013
- Delegated regulation (EU) no. 814/2013 (where applicable)

In order to constantly improve its products, the manufacturer reserves the right to change the data provided in this documentation at any time and without notice.

This documentation is provided for information purposes and cannot be considered as a contract with third parties.

# TABLE OF CONTENTS

|  |           |
|--|-----------|
| <b>Section 1 – USERS</b>   |           |
| <b>1 BOILER DESCRIPTION</b>  | <b>7</b>  |
| 1.1 Assembly view  | 7         |
| 1.2 Shut-off valves and cocks  | 7         |
| 1.3 Control panel  | 8         |
| 1.4 General LCD characteristics  | 8         |
| <b>2 USAGE INSTRUCTIONS</b>  | <b>12</b> |
| 2.1 Warnings   | 12        |
| 2.2 Ignition   | 12        |
| 2.3 Heating circuit temperature  | 13        |
| 2.4 Domestic hot water temperature   | 14        |
| 2.5 3 star preheating function   | 14        |
| 2.6 Shutdown   | 15        |
| <b>3 USEFUL TIPS</b>   | <b>16</b> |
| 3.1 Filling the heating circuit  | 16        |
| 3.2 Heating  | 16        |
| 3.3 Antifreeze protection  | 16        |
| 3.4 Periodic maintenance   | 17        |
| 3.5 External cleaning  | 17        |
| 3.6 Operating anomalies  | 17        |
| 3.7 Displays in INFO mode  | 18        |
| 3.8 Remote fault code  | 19        |
| 3.9 Flue gas sensor and thermal fuse   | 19        |
| <b>Section 2 – INSTALLERS</b>  |           |
| <b>4 TECHNICAL SPECIFICATIONS</b>  | <b>20</b> |
| 4.1 Assembly view  | 20        |
| 4.2 Schematic diagram  | 21        |
| 4.3 Wiring diagram   | 23        |
| 4.4 Technical data M375CB.2025 SM  | 24        |
| 4.5 Technical data M375CB.2530 SM  | 28        |
| 4.6 Technical data M375CB.3035 SM  | 32        |
| 4.7 Hydraulic characteristics  | 36        |
| 4.8 Expansion tank   | 36        |
| <b>5 INSTALLATION</b>  | <b>37</b> |
| 5.1 Warnings   | 37        |
| 5.2 Precautions for installation   | 38        |
| 5.3 Installing the boiler bracket  | 38        |
| 5.4 Dimensions   | 39        |
| 5.5 Fittings   | 39        |
| 5.6 Boiler assembly  | 39        |
| 5.7 Installing the flue gas exhaust duct                                       | 40        |
| 5.8 Flue gas outlet dimensions and lengths                                     | 41        |
| 5.9 C63 exhaust-flue pipework  | 44        |
| 5.10 Positioning the draught terminals   | 45        |
| 5.11 Electrical connections  | 46        |
| 5.12 Connecting a room thermostat or zone valves                               | 47        |
| 5.13 Installing the external temperature sensor                                | 48        |
| 5.14 Electric connection between the boiler and the external sensor            | 48        |
| 5.15 Selecting the type of external sensor                                     | 49        |
| 5.16 Electrical connection of the remote (optional)                            | 50        |
| 5.17 Enabling operation with the external sensor and setting the K coefficient | 50        |
| 5.18 Setting pump post-circulation   | 52        |
| 5.19 Selecting re-ignition frequency   | 54        |
| 5.20 Examples of hydraulic systems with hydraulic separator (optional)         | 55        |
| <b>6 PREPARATION FOR SERVICE</b>   | <b>57</b> |
| 6.1 Warnings   | 57        |
| 6.2 Sequence of operations   | 57        |
| <b>7 CHECKING THE GAS SETTING</b>  | <b>60</b> |
| 7.1 Warnings   | 60        |
| 7.2 Gas operations and setting   | 60        |
| 7.3 Automatic calibration of the gas valve                                     | 62        |
| <b>Section 3 – MAINTENANCE TECHNICIANS</b>                                     |           |
| <b>8 GAS CONVERSION</b>  | <b>64</b> |
| 8.1 Warnings   | 64        |
| 8.2 Gas operations and setting   | 64        |
| <b>9 MAINTENANCE</b>   | <b>66</b> |
| 9.1 Warnings   | 66        |
| 9.2 Programming the maintenance period   | 66        |
| 9.3 Removing the body panels   | 67        |
| 9.4 Reinstalling the body panels   | 68        |
| 9.5 Emptying the DHW circuit   | 68        |
| 9.6 Emptying the heating circuit   | 68        |
| 9.7 Cleaning the primary condensate exchanger and the burner                   | 69        |
| 9.8 Check the pressure in the heating expansion tank                           | 70        |
| 9.9 Cleaning the domestic hot water exchanger                                  | 70        |
| 9.10 Checking the flue gas expulsion duct                                      | 70        |
| 9.11 Checking boiler efficiency  | 70        |
| 9.12 Checking the condensate discharge siphon                                  | 71        |
| 9.13 Setting the boiler's chimney sweep function                               | 71        |
| 9.14 Settings for changing the control board                                   | 73        |
| <b>10 BOILER DISPOSAL AND RECYCLING</b>  | <b>78</b> |

| <i>Models</i> | <i>Boiler certification code</i> |
|---------------|----------------------------------|
| DINA 25S      | M375CB.2025 SM                   |
| DINA 30S      | M375CB.2530 SM                   |
| DINA 35S      | M375CB.3035 SM                   |

# BOILER DESCRIPTION

## 1 BOILER DESCRIPTION

### 1.1 Assembly view

The boiler model and serial number are printed on the warranty certificate.

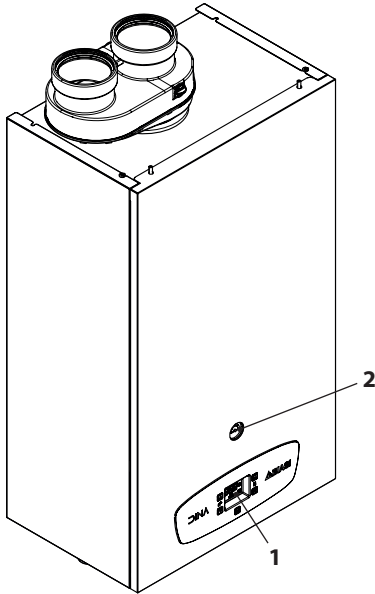

Figure 1.1

- 1 Control panel
- 2 Heating circuit pressure gauge

### 1.2 Shut-off valves and cocks

Install a shut-off cock for the DHW inlet.

The figures in this manual only show one of the possible ways of installing cocks, pipes and fittings.

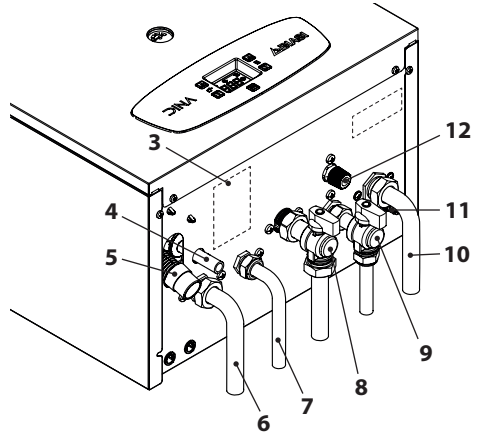

Figure 1.2

- 3 Gas supply label
- 4 Heating circuit safety valve discharge pipe
- 5 Condensate outlet pipe
- 6 Heating delivery pipe
- 7 Domestic hot water outlet pipe
- 8 Gas cock
- 9 Domestic hot water inlet cock
- 10 Heating return pipe
- 11 Heating circuit drain cock
- 12 Heating circuit filling cock

# BOILER DESCRIPTION

## 1.3 Control panel

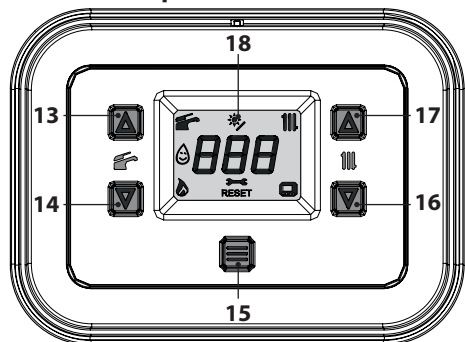

Figure 1.3

- 13 Domestic hot water temperature increase button
- 14 Domestic hot water temperature decrease button
- 15 Reset/Stand-by/Winter/Summer button
- 16 Heating temperature decrease button
- 17 Heating temperature increase button
- 18 LCD display



**The RESET that restores all parameters to the factory settings occurs only by setting "parameter P30=04". When the reset is complete, this is shown by all the symbols on the display turning on.**

## 1.4 General LCD characteristics

For the boiler technical specifications, consult the section "TECHNICAL SPECIFICATIONS" on page 20.

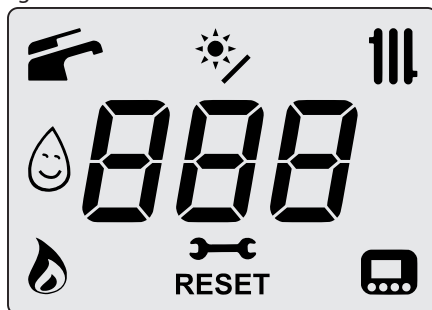



Figure 1.4









### KEY











|  |   |
|--|---|
|  | All symbols with lines radiating from them indicate that the symbol is flashing.                                |
|  | Stays on: DHW function enabled.<br>Flashing: DHW function in progress.  |
|  | Constantly illuminated: solar control unit connected.<br>Flashing: solar pump operating.                        |
|  | Stays on: heating function enabled (winter).<br>Flashing: heating function in progress.                         |
|  | Constantly illuminated: 3 star preheating function active.<br>Flashing: 3 star preheating function in progress. |
|  | Stays on: flame present<br>Flashing: drain upon ignition in progress.   |
|  | Stays on: maintenance due pre-warning.<br>Flashing: maintenance required or maintenance due.                    |

## BOILER DESCRIPTION





|   |  |
|---|--|
| <b>RESET</b>  | Stays on: lockout error. The boiler can be restarted by the user by pressing the reset button. |
|  | Stays on: remote control connected.<br>Flashing: request from remote control in progress.      |







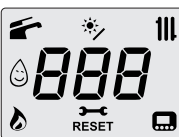

### LCD SIGNALS

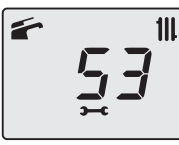
| LCD  | FUNCTION  |
|--|---|
| <b>E01 + RESET</b>   | Safety lockout due to failed ignition.  |
| <b>E02 + RESET</b>   | Lockout due to safety thermostat.   |
| <b>E03 + RESET</b>   | Generic lockout.  |
| <b>E04 + </b>   | Pump circulation failure, insufficient system pressure or pressure above 3 bar, or water pressure sensor not connected. |
| <b>E05 + </b>   | Control anomaly: fan.   |
| <b>E06 + </b>   | NTC heating delivery probe failure.   |
| <b>E07 + </b> | DHW NTC probe failure / Hot water tank sensor failure.  |
| <b>E08 + </b> | External NTC probe failure.   |
| <b>E10 + </b> | Lockout due to tripping of the flue gas probe and thermal fuse.   |
| <b>E11 + RESET</b>   | Parasite flame.   |
| <b>E12 + </b> | Return NTC probe failure.   |
| <b>E13 + </b> | Delta T M-R > 40K.  |

| LCD  | FUNCTION  |
|--|---|
| <b>E14 + RESET</b>   | Pump fault or primary temperature above 105°C.            |
| <b>E14 + </b>   | Temperature gradient circulation failure (>2K/s).         |
| <b>E15 + </b>   | Probable insufficient circulation.                        |
| <b>E16 + </b>   | Flue gas overheating detected by NTC.                     |
| <b>E18 + RESET</b>   | No ΔT heating at start-up.                                |
| <b>E19 + </b>   | Auxiliary Input Probe Anomaly.                            |
| <b>E20 + RESET</b>   | EVG lockout (valve piloting hardware failure).            |
| <b>E21 + RESET</b>   | EVG lockout (valve control Relay Failure).                |
| <b>E22 + RESET</b>   | EVG lockout (flame after closing valve Ref. EVG).         |
| <b>E23 + </b>   | Gas valve modulator disconnected.                         |
| <b>E24 + </b>   | Anomaly due to probable flue obstruction.                 |
| <b>E25 + RESET</b>   | Flame loss for more than 6 consecutive times.             |
| <b>E26 + </b> | Maximum deviation fault between the 2 heating NTC probes. |
| <b>E40 + </b> | Incorrect mains electrical supply frequency.              |
| <b>E42 + </b> | Buttons fault.  |
| <b>E44 + RESET</b>   | Fault of cumulative gas valve timeout without flame.      |
| <b>E50 + </b> | OT communication fault.                                   |
| <b>E62 + </b> | Calibration request.                                      |

## BOILER DESCRIPTION

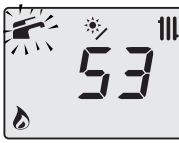
| LCD  | FUNCTION   |
|--|--|
| <b>E65 + </b> | The system cannot control combustion and exceeds the modulator's control parameters.                               |
| <b>E68 + </b> | Probable low gas pressure.   |
| <b>E77 + </b> | System outside modulator's control parameters.   |
| <b>E78 + </b> | Probable low gas pressure.   |
| <b>E79 + </b> | Modulator's control system outside parameters.   |
| <b>E89 + RESET</b>   | Internal error (usually hardware) or problems with the mains electrical supply (excessive distortion of waveform). |
| <b>E91 + RESET</b>   | Maximum number of lockouts reached.  |
| <b>E96</b>   | Incorrect network frequency.   |
| <b>E96 + RESET</b>   | After 5 E02 - E14 - E04 - E15 - E16 error events, the boiler goes into lock-out.                                   |
| <b>E97</b>   | Power supply voltage low.  |
| <b>E99</b>   | Card not configured.   |
| <b>L1</b>  | Primary limitation in DHW mode.  |
| - - -  | Boiler stand-by, the dashes light up in sequence to simulate a scrolling motion (antifreeze protection activated). |
|              | When powering ON the boiler, all icons and digits light up (for 2 seconds) to check operation of the LCD.          |

| LCD   | FUNCTION  |
|---|---|
|    | Next maintenance due date (factory setting 12 months). In the event of an error, this has greater priority than maintenance due date. |
|    | Maintenance overdue. In the event of an error, this has greater priority than maintenance due date.                                   |
|    | Pump active for the post-circulation phase (flashing <b>PO</b> + flashing temperature).   |
|    |   |
|    | Boiler in antifreeze phase (flashing <b>bP</b> + flashing temperature).   |
|  |   |
|  | Boiler with DHW power request. The DHW temperature is displayed.  |
|  | Boiler with central heating request via room thermostat.  |

## BOILER DESCRIPTION

| LCD | FUNCTION  |
|-----|---|
|     | Boiler with central heating power request with connected remote.  |
|     | Heating set temperature (all other symbols are disabled).   |
|     | DHW set temperature (all other symbols are disabled).   |
|     | Delay burner ignition due to system setting (flashing uu + flashing temperature).   |
|     |   |
|     | Boiler in chimney sweep function.<br>To activate the chimney sweep function, set "parameter P32=1 ... 4". The following is displayed:<br>LP = minimum DHW<br>hP = minimum output in heating mode<br>cP = maximum output in heating mode<br>dP=maximum DHW.<br>The transition occurs with buttons 17 (increase) and 14 (decrease) DHW temperature. |
|     |   |

| LCD | FUNCTION   |
|-----|--|
|     | 3 star preheating function active.<br>When the symbol  flashes, the function is in process.                                |
|     | Constantly illuminated: solar control unit connected.<br>When the symbol  flashes, the solar circuit pump is in operation. |

# USAGE INSTRUCTIONS

## 2 USAGE INSTRUCTIONS

### 2.1 Warnings



Check that the heating circuit is correctly filled with water, even if the boiler is only used for producing domestic hot water.

If it is not, fill the circuit. See section "Filling the heating circuit" on page 16.

All boilers have an antifreeze system that is activated if the temperature falls below 5°C; therefore **do not turn off the boiler**.

If the boiler is not used during cold periods, with the resulting risk of freezing, proceed as described in section "Antifreeze protection" on page 16.

### 2.2 Ignition

- The boiler cocks and the cocks used during installation must be open (Figure 2.1).

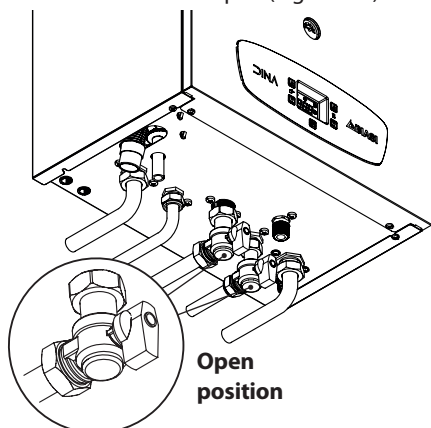

Figure 2.1

- Power the boiler by turning on the two-way switch fitted during installation. The LCD display shows the boiler status (last stored) Figure 2.2.



Stand-by  
The dashes light up in sequence to simulate a scrolling motion



Winter

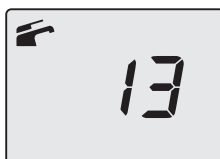



Summer

Figure 2.2

When the boiler is in Winter or Summer mode and there is no heat request, the display shows the pressure in the heating circuit (e.g. 1.3 bar in Figure 2.2).

### Heating/DHW operation

- Press button 15 for 1 seconds until both symbols  and  appear on the display (Figure 2.3).

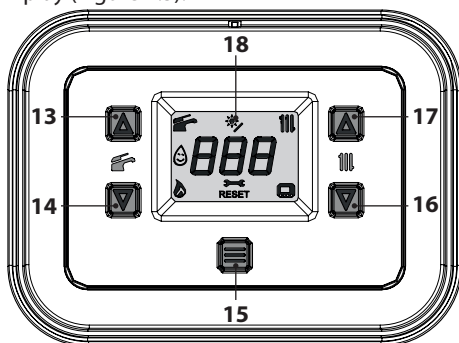



Figure 2.3

The LCD display shows the boiler temperature (primary circuit) and the symbols  and  (Figure 2.4).

# USAGE INSTRUCTIONS

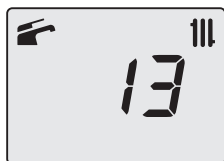



Figure 2.4

## Operation with production of hot water only

- Press button 15 for 1 second until the symbol  appears on the display (Figure 2.5).

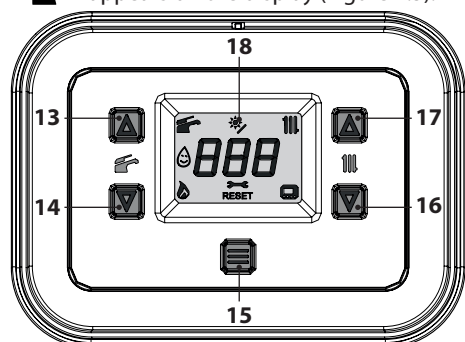

Figure 2.5

The LCD display shows the boiler temperature (primary circuit) and the symbol  (Figure 2.6).



Figure 2.6

## 2.3 Heating circuit temperature

The heating delivery temperature of the hot water can be adjusted using the buttons 16 (decrease) and 17 (increase) (Figure 2.5) to between a minimum of approx. 25°C and a maximum of approx. 80°C. The first time one of those buttons is pressed, the "set" value is displayed. The second time it is pressed this can be changed.

Signal on the LCD display:

- the set value of the heating delivery hot water temperature and the  symbol flash. The display background lights up (Figure 2.7).



Figure 2.7

## Adjusting the heating temperature based on the outdoor temperature (without external sensor)

Adjust the heating delivery hot water temperature as follows:

- between 25 and 35 with an external temperature between 5 and 15°C
- from 35 to 60 with an outdoor temperature of between -5°C and +5°C
- from 60 to 80 with an outdoor temperature of below -5°C.

Your qualified installer may suggest more suitable settings for your system.

The set temperature has been reached when the  symbol is not visible on the LCD display.

## Heating power demand



When the boiler receives a heating power request, the display shows the  symbol followed by an increase in the heating delivery water temperature. The  symbol flashes (Figure 2.8).



Figure 2.8

# USAGE INSTRUCTIONS

## Adjusting the heating temperature with an external sensor installed

When the external sensor (optional) is installed, your boiler will automatically adjust the heating system's delivery water temperature according to the outdoor temperature.

In this case, the boiler must be set by a qualified installer (see "Enabling operation with the external sensor and setting the K coefficient" on page 50).

If the room temperature is not comfortable, increase or decrease the heating system delivery temperature by  $\pm 15^{\circ}\text{C}$  using the 16 (decrease) and 17 (increase) buttons (Figure 2.5).

USERS

## 2.4 Domestic hot water temperature

The domestic hot water temperature can be adjusted using the 13 (increase) and 14 (decrease) buttons (Figure 2.5) from a minimum of approx.  $35^{\circ}\text{C}$  to a maximum of approx.  $60^{\circ}\text{C}$ . The first time one of these two buttons is pressed, the "set" value is displayed. The second time it is pressed, the value can be changed.

Signal on the LCD display:

- the set value of the domestic hot water and the  symbol flash. The display background lights up (Figure 2.7).



Figure 2.9

## Adjustments

Adjust the temperature of the domestic hot water to a value that suits your needs. Limit the need to mix hot water with cold water.

In this way, you can take full advantage of the automatic setting.

If the water is particularly hard, we recommend setting the boiler temperature to below  $50^{\circ}\text{C}$ .

In such cases, we recommend installing a water softener in the DHW system.

If the maximum flow rate of the domestic hot water is too high for a sufficient temperature to be reached, contact an authorised support technician to install a flow rate limiter.

## Domestic hot water demand



When the boiler receives a request for domestic hot water, the  symbol shows on the display followed by an increase in the temperature of the domestic hot water. The  symbol flashes (Figure 2.10).



Figure 2.10

## 2.5 3 star preheating function

This function reduces consumption of the domestic hot water supply at the time of withdrawal, preparing the boiler temperature at the requested temperature.

To activate the 3 star preheating function press keys 13 and 14 together (Figure 2.12) until the symbol  appears on the LCD display.

When the symbol  flashes, the function is in process.

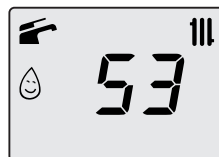



Figure 2.11

N.B.: should the power to the boiler fail, wait at least one minute before activating the function upon reactivation.

To disable the 3 star preheating function press keys 13 and 14 (Figure 2.12) until the symbol  disappears from the LCD display.

# USAGE INSTRUCTIONS

## 2.6 Shutdown

Press button 15 (Figure 2.12) for 5 seconds until the symbol **- - -** appears on the display (the dashes light up in sequence to simulate a scrolling motion) (Figure 2.13).

- If necessary, empty the hydraulic circuits (see section “Emptying the DHW circuit” on page 68 and section “Emptying the heating circuit” on page 68).

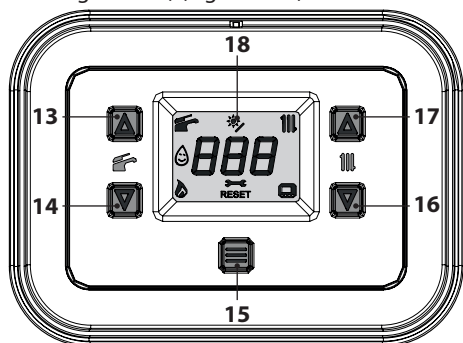

Figure 2.12



Figure 2.13

If the boiler will be inactive for a long period of time:

- Disconnect the boiler from the electric power supply;
- Close the boiler cocks Figure 2.14;

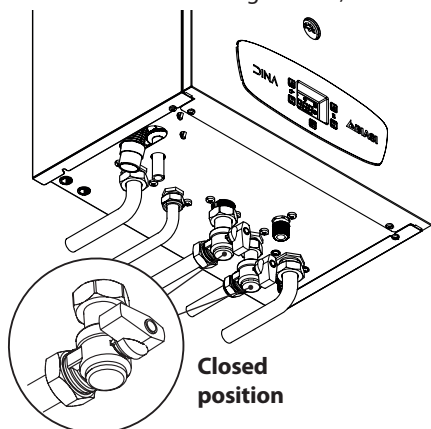

Figure 2.14

## USEFUL TIPS

### 3 USEFUL TIPS

#### 3.1 Filling the heating circuit

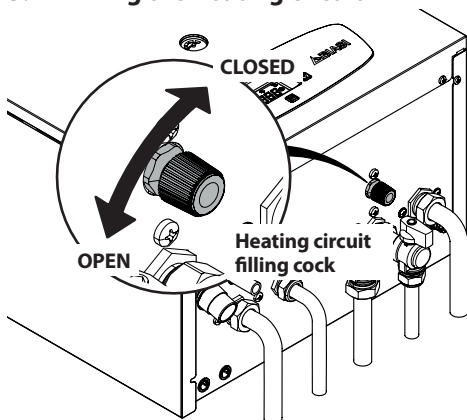

Figure 3.1

Open the filling cock in Figure 3.1 located under the boiler and check the heating circuit pressure on the pressure gauge at the same time. The correct cold system pressure value should be within the first green bar on the pressure gauge quadrant (Figure 3.2).

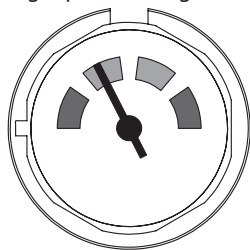

Figure 3.2

When the operation is complete, close the filling cock and bleed any air from the radiators.

#### 3.2 Heating

For rational and economical service, have a room thermostat installed.

Never turn off the radiator in the room where the room thermostat is installed.

If a radiator (or convector) does not heat up, check if there is any air in the system and make

sure that the cock is open.

If the room temperature is too high, do not adjust the radiator cocks but decrease the heating temperature setting using the room thermostat or the heating control buttons 16 and 17 (Figure 3.3).

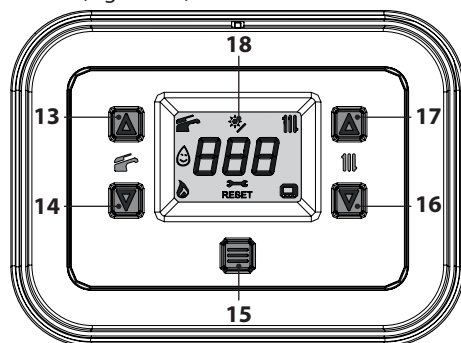

Figure 3.3

#### 3.3 Antifreeze protection

The antifreeze system, and any additional protective devices, safeguard the boiler against possible damage due to freezing.

This system does not guarantee protection for the entire hydraulic system.

Where the outdoor temperature could fall below 0°C, it is recommended to leave the entire system on, setting the room thermostat to a low temperature.

The antifreeze function is active even if the boiler is in stand-by (Figure 3.4).



Figure 3.4

If the boiler is turned off, have a qualified technician empty the boiler (heating and DHW circuit) and empty the heating system and the DHW system.

## USEFUL TIPS

### 3.4 Periodic maintenance

For efficient and regular boiler operation, it is recommended that the boiler be serviced and cleaned at least once a year by a technician from an authorised service centre.

During this check, the most important boiler components are inspected and cleaned. This check may be performed within the scope of a maintenance contract.

### 3.5 External cleaning



**Before performing any cleaning operation, disconnect the boiler from the electric mains supply.**

To clean, use a cloth soaked in soap and water. **Do not use:** Solvents, flammable substances or abrasive substances.

### 3.6 Operating anomalies

If the boiler is not operating and a code appears on the LCD display that is preceded by the letter "E" and the message **RESET** (see "General LCD characteristics" on page 8) the boiler is in lockout. The display background will flash (Figure 3.5).

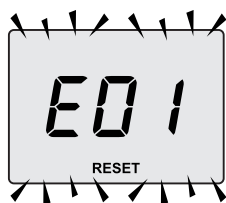

Figure 3.5

To restore operation, press the reset button 15 (Figure 3.3) on the boiler control panel.



**Frequent safety lockouts should be reported to an authorised service centre.**

After three reset attempts made by pressing the reset key 15 (Figure 3.3), code "E91" and



the symbol  (Figure 3.6) appear on the LCD display. The boiler is in lockout mode.



Figure 3.6

To restore boiler operation, disconnect the electrical power supply. Then, reconnect it and press buttons 13, 14 and 15 (Figure 3.3) on the boiler control panel at the same time for at least 5s.

### Other possible anomalies shown on the LCD display

If the LCD display shows a code preceded by the letter **E** and the symbol  the boiler has an anomaly that cannot be reset.

The display background will flash (Figure 3.7).



Figure 3.7

Another possible notification occurs when the DHW exchanger is not able to exchange all the power delivered by the boiler.

E.g. DHW exchanger blocked by lime scale. This occurs only when domestic hot water is requested from the boiler.

Code **L1** appears on the LCD display. The display background will flash (Figure 3.8).



Figure 3.8

**!** To restore correct boiler operation, contact a technician from an authorised service centre.

### Air bubble noises

Check the pressure of the heating circuit and fill it if necessary, see section “Filling the heating circuit” on page 16.

### Low system pressure

Add more water to the heating system. To do this, refer to section “Filling the heating circuit” on page 16.

The user is responsible for periodically checking the pressure of the heating system. If water needs to be added too often, have the technical support centre check if there are any leaks in the heating system or the boiler itself.

### Water leaks from the safety valve

Check if the filling cock is closed tightly (see “Filling the heating circuit” on page 16). Check on the pressure gauge that the heating circuit pressure is not close to 3 bar. Should this be the case, drain a part of the water from the system through the air relief valves in the radiators in order to reduce the pressure to a normal value.

**!** In the case of malfunctions other than those described above, shut down the boiler as described in section “Shutdown” on page 15 and call a technician from the authorised service centre.

### 3.7 Displays in INFO mode

INFO mode is used to view boiler operating status information. In the case of a boiler malfunction, provide this information to the service centre so that they can identify the cause.

To access the INFO mode, press buttons 16 and 17 (Figure 3.9) together until the index “J00” is shown on the display, alternating with the parameter value (Figure 3.10).

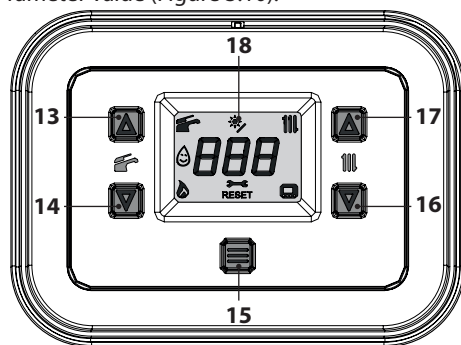

Figure 3.9



Figure 3.10

To scroll through the values, press the 14 key (previous INFO) and 16 key (next INFO).

To exit INFO mode, simply:

- wait 15 minutes without pressing any key;
- switch off the electric power supply;
- press and hold the 14 and 16 keys simultaneously for 5 seconds (Figure 3.9) (one level up).

## USEFUL TIPS

The table summarises the possible values visible in INFO mode.

| Value shown  | Table of contents |
|--|-------------------|
| Primary circuit pressure   | J00 + ---         |
| Outdoor temperature  | J01 + value       |
| K curve value configured on site                                     | J02 + value       |
| Offset climatic curve value  | J03 + value       |
| Calculated heating set point (with climatic curve or set configured) | J04 + value       |
| Delivery NTC temperature   | J05 + value       |
| Return NTC temperature   | J06 + value       |
| DHW set  | J07 + value       |
| DHW inlet temperature (if foreseen)                                  | J08 + ---         |
| DHW outlet temperature   | J09 + value       |
| DHW capacity   | J10 + value       |
| Flue gases temperature (if foreseen)                                 | J11 + ---         |
| Fan speed  | J12 + value       |
| Flue gas pressure transducer (if foreseen)                           | J13 + ---         |
| Ionisation current value   | J14 + value       |
| Number of months to maintenance                                      | J15 + value       |
| 3 star status (ON=01, OFF=00)  | J16 + value       |
| Modulation percentage  | J17 + value       |
| Pump modulation percentage   | J18 + value       |
| Delivery 2 temperature (if foreseen)                                 | J19 + value       |
| M.B. version   | J20 + value       |
| Main SW version  | J21 + value       |

### 3.8 Remote fault code

If the optional remote is connected to the boiler, a code can be shown on the central part of

the display that indicates a boiler anomaly. The current anomaly is indicated by a numeric code followed by the letter **E**.

The fault codes sent to the remote are the same as those shown on the display (see "LCD SIGNALS" on page 9).

### 3.9 Flue gas sensor and thermal fuse



**Thermal fuse tripping involves a safety lockout, and requires resetting by an Authorised Service Centre.**

The flue gas sensor and thermal fuse 19 indicated in Figure 3.11 are safety devices.

The flue gas sensor and 19 are triggered when the flue gas temperature exceeds 110°C, activating the boiler safety lockout, shutting it off. To reset normal boiler operation simply press the button 15 (Figure 3.9).

If the flue sensor 19 does not trip and, therefore does not send the boiler into safety lockout, the thermal fuse 19 activates as a further measure to protect the flue gas outlet.

To restore the normal operation of the boiler, contact the Authorised Service Centre.

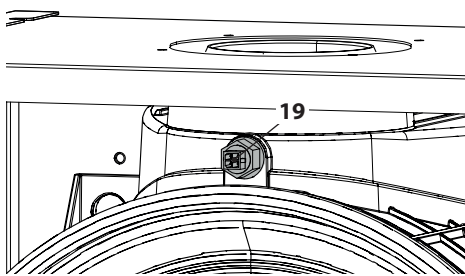
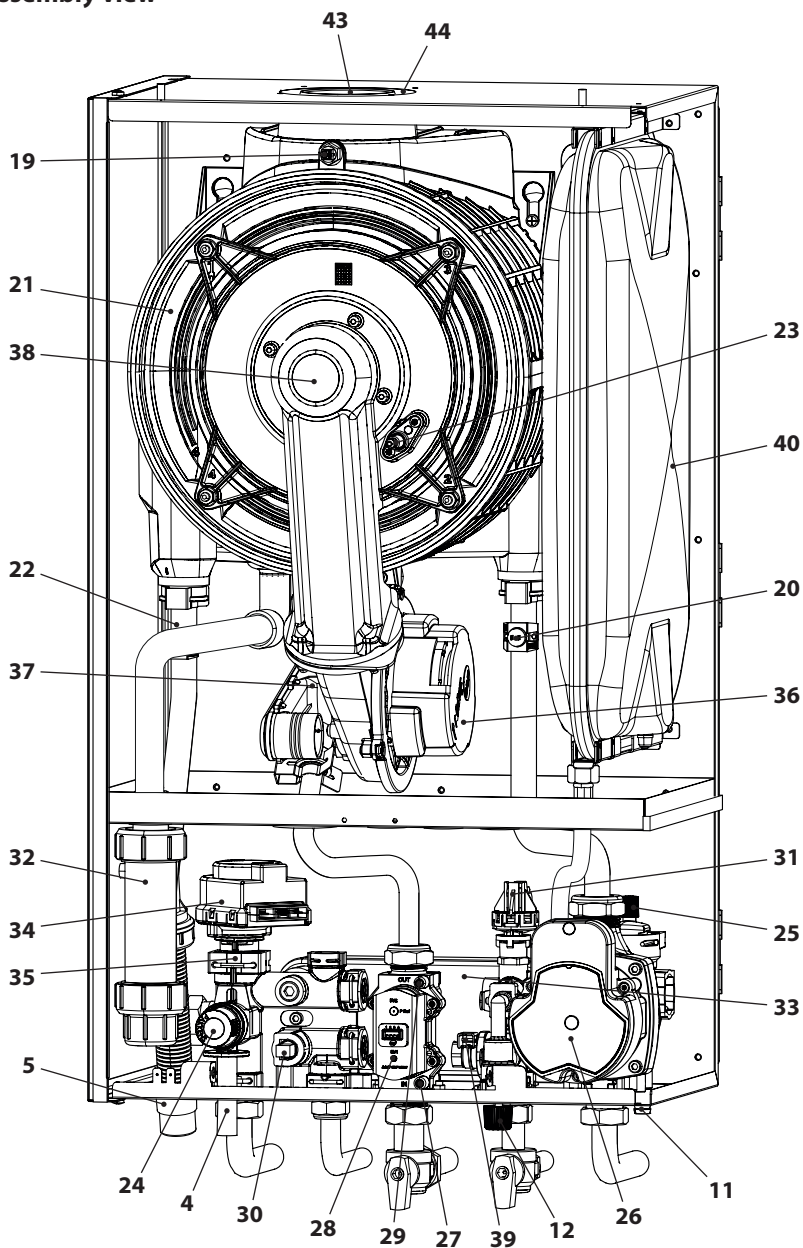

Figure 3.11

# TECHNICAL SPECIFICATIONS

## 4 TECHNICAL SPECIFICATIONS

### 4.1 Assembly view



INSTALLERS

Figure 4.1

# TECHNICAL SPECIFICATIONS

## 4.2 Schematic diagram

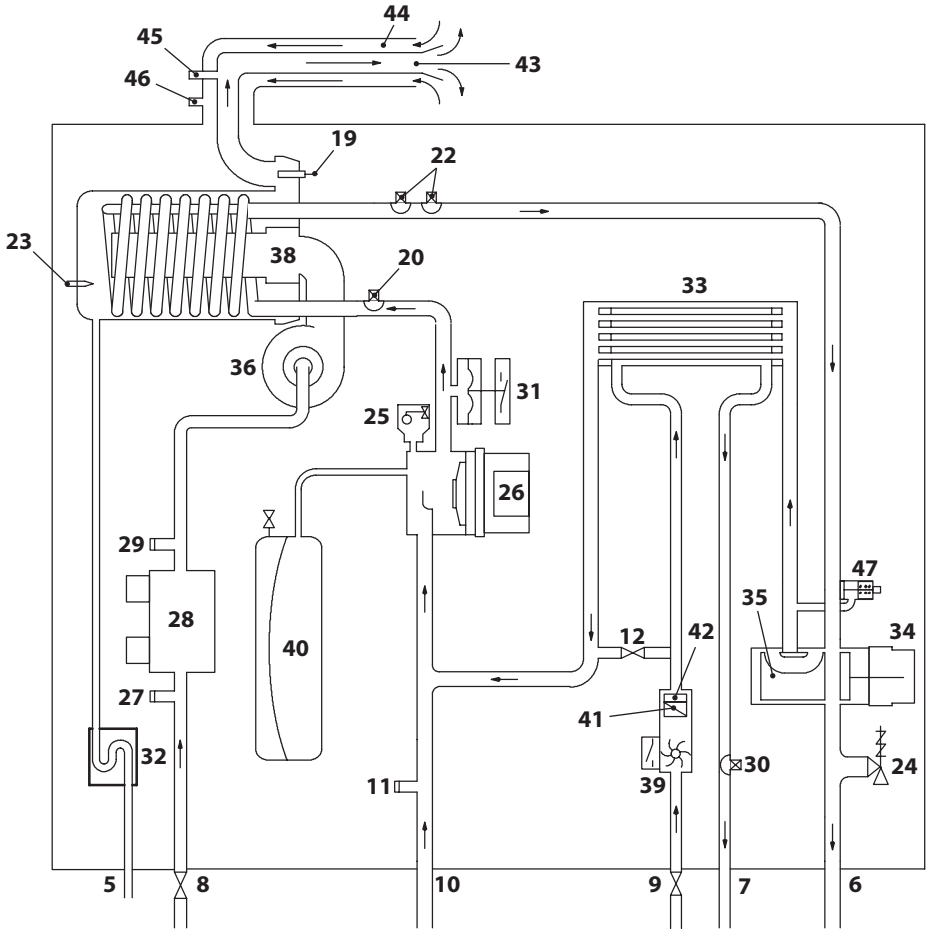

Figure 4.2

- |   |   |
|---|---|
| 4 Heating circuit safety valve discharge pipe | 20 Heating NTC return probe                             |
| 5 Condensate outlet pipe                      | 21 Primary condensing exchanger                         |
| 6 Heating delivery pipe                       | 22 NTC heating delivery probe - NTC maximum temperature |
| 7 Domestic hot water outlet pipe              | 23 Flame detection electrode/ignition electrode         |
| 8 Gas cock                                    | 24 3 bar safety valve                                   |
| 9 Domestic hot water inlet cock               | 25 Automatic bleed valve                                |
| 10 Heating return pipe                        | 26 Pump   |
| 11 Heating circuit drain cock                 | 27 Gas valve inlet tapping point                        |
| 12 Heating circuit filling cock               |   |
| 19 Flue gas NTC sensor and thermal fuse       |   |

---

## TECHNICAL SPECIFICATIONS

---

- 28 Gas valve
- 29 Gas valve outlet tapping point
- 30 DHW NTC probe
- 31 Heating pressure switch
- 32 Condensate outlet siphon
- 33 DHW exchanger
- 34 Three-way valve
- 35 Three-way valve plug
- 36 Fan
- 37 Air/gas mixer
- 38 Burner
- 39 DHW flowmeter
- 40 Expansion tank
- 41 Domestic hot water filter
- 42 DHW flow rate limiter (optional)
- 43 Flue gas exhaust duct
- 44 Air suction duct
- 45 Flue gas suction inlet
- 46 Air suction inlet
- 47 Integrated by-pass

\* To access the *Data plate*, remove the front panel from the body as described in the *Maintenance* section.

# TECHNICAL SPECIFICATIONS

## 4.3 Wiring diagram

|   |  |    |                                 |    |   |
|---|--|----|---------------------------------|----|---|
| 1 | Electrical power supply                        | 6  | Fan                             | 11 | Gas valve                               |
| 2 | Three-way valve                                | 7  | Flue gas probe and thermal fuse | 12 | External sensor terminal board          |
| 3 | Pump   | 8  | DHW flowmeter                   | 13 | Remote terminal board – Room thermostat |
| 4 | NTC heating return                             | 9  | DHW NTC                         | 14 | Ignition and detection electrodes       |
| 5 | NTC heating delivery / NTC maximum temperature | 10 | Heating pressure switch         |    |   |

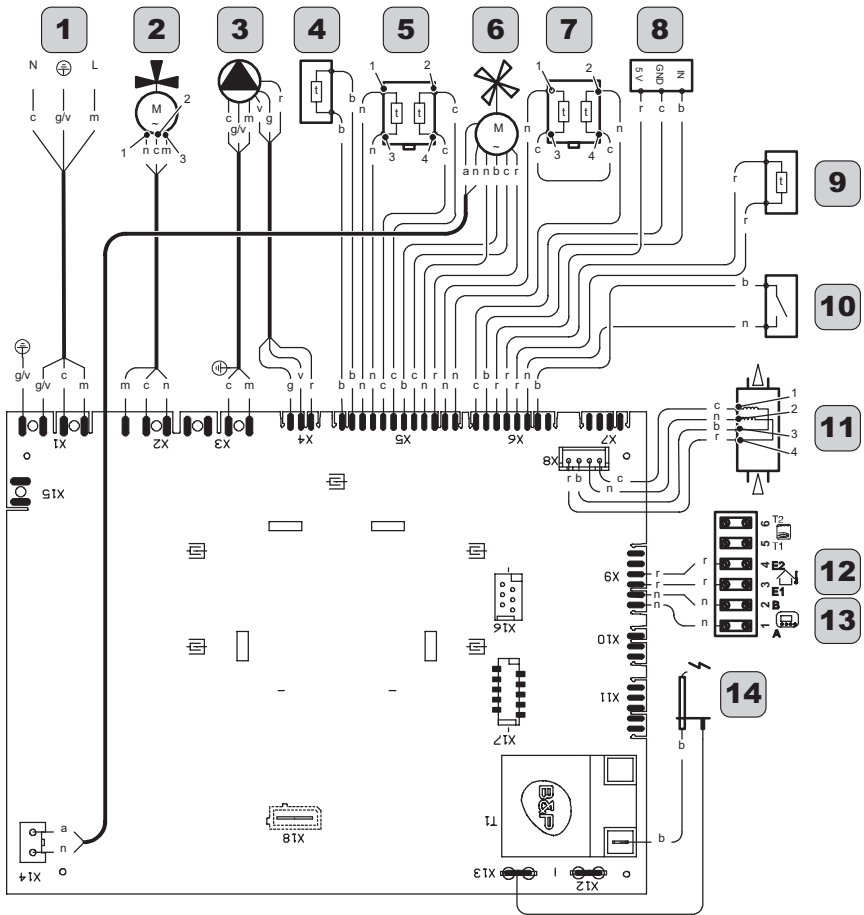

|   |        |    |        |   |        |     |              |
|---|--------|----|--------|---|--------|-----|--------------|
| a | orange | g  | yellow | n | black  | y/g | yellow/green |
| b | white  | gr | grey   | r | red    |     |              |
| c | blue   | m  | brown  | v | purple |     |              |

Figure 4.3

INSTALLERS

# TECHNICAL SPECIFICATIONS

## 4.4 Technical data M375CB.2025 SM

|  |        |       |
|--|--------|-------|
| (nom.Q.) Nominal heat input in heating mode (Hi)                       | kW     | 21,0  |
|  | kcal/h | 18057 |
| (nom.Q.) Nominal heat input in heating mode (Hi) with 20% H2NG mixture | kW     | 18,7  |
|  | kcal/h | 16079 |
| (nom.Q.) Nominal heat input in d.h.w. mode (Hi)                        | kW     | 26,0  |
|  | kcal/h | 22356 |
| (nom.Q.) Nominal heat input in DHW mode (Hi) with 20% H2NG mixture     | kW     | 22,5  |
|  | kcal/h | 19347 |
| (nom.Q.) Minimum heat input (Hi)                                       | kW     | 5,2   |
|  | kcal/h | 4471  |
| * Max. heat output in heating mode 60°/80°C                            | kW     | 20,7  |
|  | kcal/h | 17799 |
| * Max. heat output in d.h.w. mode 60°/80°C                             | kW     | 25,6  |
|  | kcal/h | 22012 |
| * Min. heat output 60°/80°C  | kW     | 4,9   |
|  | kcal/h | 4213  |
| ** Max. heat output in heating mode 30°/50°C                           | kW     | 22,6  |
|  | kcal/h | 19433 |
| ** Max. heat output in d.h.w. mode 30°/50°C                            | kW     | 28    |
|  | kcal/h | 24076 |
| ** Min. heat output 30°/50°C   | kW     | 5,5   |
|  | kcal/h | 4729  |

| Data in heating mode                      |        |            |
|---|--------|------------|
| NOx class                                 |        | 6          |
| Weighted NOx ***                          | mg/kWh | 31         |
|   | ppm    | 18         |
| CO at nom. Q. (0% O2) ***                 | ppm    | 170,0      |
| CO at nom. Q. (0% O2) ***                 | ppm    | 15,0       |
| CO2 at nom. Q. with G20                   | %      | 8,5 - 9,5  |
| CO2 at min. Q. with G20                   | %      | 8,5 - 9,5  |
| CO2 at nom. Q. with G31                   | %      | 9,5 - 10,5 |
| CO2 at min. Q. with G31                   | %      | 9,5 - 10,5 |
| ** Condensate quantity at nom.Q. 30°/50°C | l/h    | 4,2        |
| ** Condensate quantity at min.Q. 30°/50°C | l/h    | 0,8        |
| Condensate pH                             | pH     | 4,0        |

| Data in d.h.w. mode     |   |            |
|-------------------------|---|------------|
| CO2 at nom. Q. with G20 | % | 8,5 - 9,5  |
| CO2 at min. Q. with G20 | % | 8,5 - 9,5  |
| CO2 at nom. Q. with G31 | % | 9,5 - 10,5 |
| CO2 at min. Q. with G31 | % | 9,5 - 10,5 |
| O2 at nom. Q. with G20  | % | 4,2 + 6,6  |
| O2 at min. Q. with G20  | % | 4,2 + 6,6  |

\* With return water temperature that does not permit condensation

\*\* With return water temperature that does permits condensation

\*\*\* With coax. flue gas discharge 60/100 0.9 m and METHANE gas G20

# TECHNICAL SPECIFICATIONS

| Measured efficiency in heating mode  |          |       |
|--|----------|-------|
| * Nominal efficiency 60°/80°C  | %        | 98,58 |
| * Min. efficiency 60°/80 C   | %        | 94,0  |
| ** Nominal efficiency 30°/50°C   | %        | 107,8 |
| ** Min. efficiency 30°/50°C  | %        | 105,9 |
| ** Efficiency At 30 % of load  | %        | 109,8 |
| Heat loss at the chimney with burner operating                                 | Pf (%)   | 1,1   |
| Heat loss at the chimney with burner off $\Delta T$ 50°C                       | Pfbs (%) | 0,2   |
| Heat loss towards the environment through the casing with the burner operating | Pd (%)   | 0,3   |

| Gas supply pressures |             |      |      |
|----------------------|-------------|------|------|
| Gas                  |             | Pa   | mbar |
| Methane G20          | <b>Nom.</b> | 2000 | 20   |
|                      | <b>Min.</b> | 1700 | 17   |
|                      | <b>Max.</b> | 2500 | 25   |
| Propane G31          | <b>Nom.</b> | 3700 | 37   |
|                      | <b>Min.</b> | 2500 | 25   |
|                      | <b>Max.</b> | 4500 | 45   |

| Gas rate maximum - central heating    |      |      |
|---------------------------------------|------|------|
| Methane G20                           | m³/h | 2,22 |
| Propane G31                           | kg/h | 1,63 |
| Gas rate maximum - domestic hot water |      |      |
| Methane G20                           | m³/h | 2,75 |
| Propane G31                           | kg/h | 2,02 |
| Gas rate minimum - ch dhw             |      |      |
| Methane G20                           | m³/h | 0,56 |
| Propane G31                           | kg/h | 0,40 |

| Heating                                     |     |         |
|---|-----|---------|
| Adjustable temperature *                    | °C  | 25 - 80 |
| Max. operating temp.                        | °C  | 90      |
| Maximum pressure                            | kPa | 300     |
|   | bar | 3,0     |
| Minimum pressure                            | kPa | 30      |
|   | bar | 0,3     |
| Available pressure difference (at 1000 l/h) | kPa | 41,0    |
|   | bar | 0,410   |

\* At minimum useful power

| Domestic hot water                             |       |         |
|--|-------|---------|
| Temp. Minimum-Maximum                          | °C    | 35 - 55 |
| Maximum pressure                               | kPa   | 1000    |
|  | bar   | 10      |
| Minimum pressure                               | kPa   | 30      |
|  | bar   | 0,3     |
| Maximum flow rate<br>( $\Delta T=25$ K)        | l/min | 14,9    |
|  | l/min | 10,4    |
| Minimum flow rate<br>( $\Delta T=35$ K)        | l/min | 2,5     |
|  | l/min | 12,5    |
| Specific d.h.w. flow rate ( $\Delta T=30$ K) * | l/min | 12,5    |

\* Reference standard EN 625

| Chimney design #                      |      |        |
|---------------------------------------|------|--------|
| Max. flue gas temperature at 60°/80°C | °C   | 76     |
| Max. flue gas temperature at 30°/50°C | °C   | 36     |
| Max. flue gas mass flow rate          | kg/s | 0,0120 |
| Min. flue gas mass flow rate          | kg/s | 0,0024 |
| Max. air mass flow rate               | kg/s | 0,0116 |
| Min. air mass flow rate               | kg/s | 0,0023 |

# Values refer to tests with 80 mm 1 + 1 twin pipe discharge Methane gas G20 and heat input in d.h.w. mode

# TECHNICAL SPECIFICATIONS

| Electrical data              |       |     |
|------------------------------|-------|-----|
| Voltage                      | V     | 230 |
| Frequency                    | Hz    | 50  |
| Output at nominal heat input | W     | 94  |
| Output in stand-by           | W     | 3   |
| Degree of protection         | IPX5D |     |

| Other characteristics    |                 |      |
|--------------------------|-----------------|------|
| Height                   | mm              | 700  |
| Width                    | mm              | 400  |
| Depth                    | mm              | 268  |
| Weight                   | kg              | 31,5 |
| Water content in boiler  | dm <sup>3</sup> | 2    |
| Min. ambient temperature | °C              | -5   |
| Max. ambient temperature | °C              | 40   |

| Flue gas discharges                 |    |        |
|-------------------------------------|----|--------|
| Boiler type                         |    |        |
| B23P C13 C33 C43 C53 C63 C83 C93    |    |        |
| Coaxial air/flue gas duct Ø         | mm | 60/100 |
| Twin pipe air/flue gas duct Ø       | mm | 80/80  |
| Coaxial air/flue gas duct to roof Ø | mm | 80/125 |

G20 Hi. 34.02 MJ/m<sup>3</sup> (15°C, 1013.25 mbar)

G31 Hi. 46.34 MJ/kg (15°C, 1013.25 mbar)

1 mbar corresponds to approx. 10 mm H<sub>2</sub>O

(2855)

# TECHNICAL SPECIFICATIONS

|   |                       |
|---|-----------------------|
| Model(s):                                     | <b>M375CB.2025 SM</b> |
| Condensing boiler:                            | Si                    |
| Low-temperature boiler (**):                  | No                    |
| B1 boiler:                                    | No                    |
| Cogeneration space heater:                    | No                    |
| If yes, equipped with a supplementary heater: | -                     |
| Combination heater:                           | Si                    |

| Item                     | Symbol      | Value     | Unit      |
|--------------------------|-------------|-----------|-----------|
| <b>Rated heat output</b> | $P_{rated}$ | <b>21</b> | <b>kW</b> |

|   |       |      |    |
|---|-------|------|----|
| For boiler space heaters and boiler combination heaters: Useful heat output |       |      |    |
| At rated heat output and high-temperature regime (*)                        | $P_4$ | 20,7 | kW |
| At 30% of rated heat output and low-temperature regime (**)                 | $P_1$ | 6,9  | kW |

|                                   |            |       |    |
|-----------------------------------|------------|-------|----|
| Auxiliary electricity consumption |            |       |    |
| At full load                      | $el_{max}$ | 0,025 | kW |
| At part load                      | $el_{min}$ | 0,012 | kW |
| In standby mode                   | $P_{SB}$   | 0,003 | kW |

For combination heaters:

|                                |            |       |     |
|--------------------------------|------------|-------|-----|
| <b>Declared load profile</b>   | XL         |       |     |
| Daily electricity consumption  | $Q_{elec}$ | 0,170 | kWh |
| Annual electricity consumption | AEC        | 37    | kWh |

| Item  | Symbol   | Value     | Unit     |
|---|----------|-----------|----------|
| <b>Seasonal space heating energy efficiency</b> | $\eta_s$ | <b>94</b> | <b>%</b> |
| Seasonal energy efficiency class                |          | <b>A</b>  |          |

|  |          |      |   |
|--|----------|------|---|
| For boiler space heaters and boiler combination heaters: Useful efficiency |          |      |   |
| At rated heat output and high-temperature regime (*)                       | $\eta_4$ | 88,8 | % |
| At 30% of rated heat output and low-temperature regime (**)                | $\eta_1$ | 98,8 | % |

|                                   |           |       |        |
|-----------------------------------|-----------|-------|--------|
| Other items                       |           |       |        |
| Standby heat loss                 | $P_{sby}$ | 0,110 | kW     |
| Ignition burner power consumption | $P_{ign}$ | -     | kW     |
| Annual energy consumption         | $Q_{HE}$  | 63    | GJ     |
| Sound power level, indoors        | $L_{WA}$  | 49    | dB     |
| Emission of nitrogen oxides       | $NO_x$    | 31    | mg/kWh |

**INSTALLERS**

Contact details See manual cover

(\*) High-temperature regime means 60°C return temperature at heater inlet and 80°C feed temperature at heater outlet.

(\*\*) Low temperature means for condensing boilers 30°C, for low-temperature boilers 37°C and for other heaters 50°C return temperature (at heater inlet).

# TECHNICAL SPECIFICATIONS

## 4.5 Technical data M375CB.2530 SM

|  |        |       |
|--|--------|-------|
| (nom.Q.) Nominal heat input in heating mode (Hi)                       | kW     | 26,0  |
|  | kcal/h | 22356 |
| (nom.Q.) Nominal heat input in heating mode (Hi) with 20% H2NG mixture | kW     | 22,5  |
|  | kcal/h | 19347 |
| (nom.Q.) Nominal heat input in d.h.w. mode (Hi)                        | kW     | 31,0  |
|  | kcal/h | 26655 |
| (nom.Q.) Nominal heat input in DHW mode (Hi) with 20% H2NG mixture     | kW     | 27,2  |
|  | kcal/h | 23388 |
| (nom.Q.) Minimum heat input (Hi)                                       | kW     | 6,2   |
|  | kcal/h | 5331  |
| * Max. heat output in heating mode 60°/80°C                            | kW     | 25,7  |
|  | kcal/h | 22098 |
| * Max. heat output in d.h.w. mode 60°/80°C                             | kW     | 30,6  |
|  | kcal/h | 26311 |
| * Min. heat output 60°/80°C  | kW     | 5,9   |
|  | kcal/h | 5073  |
| ** Max. heat output in heating mode 30°/50°C                           | kW     | 27,9  |
|  | kcal/h | 23990 |
| ** Max. heat output in d.h.w. mode 30°/50°C                            | kW     | 33,3  |
|  | kcal/h | 28633 |
| ** Min. heat output 30°/50°C   | kW     | 6,5   |
|  | kcal/h | 5589  |

| Data in heating mode                      |        |            |
|---|--------|------------|
| NOx class                                 |        | 6          |
| Weighted NOx ***                          | mg/kWh | 35         |
|   | ppm    | 20         |
| CO at nom. Q. (0% O2) ***                 | ppm    | 170,0      |
| CO at nom. Q. (0% O2) ***                 | ppm    | 6,0        |
| CO2 at nom. Q. with G20                   | %      | 8,5 - 9,5  |
| CO2 at min. Q. with G20                   | %      | 8,5 - 9,5  |
| CO2 at nom. Q. with G31                   | %      | 9,5 - 10,5 |
| CO2 at min. Q. with G31                   | %      | 9,5 - 10,5 |
| ** Condensate quantity at nom.Q. 30°/50°C | l/h    | 5,0        |
| ** Condensate quantity at min.Q. 30°/50°C | l/h    | 0,9        |
| Condensate pH                             | pH     | 4,0        |

| Data in d.h.w. mode     |   |            |
|-------------------------|---|------------|
| CO2 at nom. Q. with G20 | % | 8,5 - 9,5  |
| CO2 at min. Q. with G20 | % | 8,5 - 9,5  |
| CO2 at nom. Q. with G31 | % | 9,5 - 10,5 |
| CO2 at min. Q. with G31 | % | 9,5 - 10,5 |
| O2 at nom. Q. with G20  | % | 4,2 + 6,6  |
| O2 at min. Q. with G20  | % | 4,2 + 6,6  |

\* With return water temperature that does not permit condensation

\*\* With return water temperature that does permits condensation

\*\*\* With coax. flue gas discharge 60/100 0.9 m and METHANE gas G20

# TECHNICAL SPECIFICATIONS

| Measured efficiency in heating mode  |          |  |       |
|--|----------|--|-------|
| * Nominal efficiency 60°/80°C  | %        |  | 98,69 |
| * Min. efficiency 60°/80 C   | %        |  | 95,0  |
| ** Nominal efficiency 30°/50°C   | %        |  | 107,4 |
| ** Min. efficiency 30°/50°C  | %        |  | 105,5 |
| ** Efficiency At 30 % of load  | %        |  | 109,7 |
| Heat loss at the chimney with burner operating                                 | Pf (%)   |  | 1,1   |
| Heat loss at the chimney with burner off $\Delta T$ 50°C                       | Pfbs (%) |  | 0,2   |
| Heat loss towards the environment through the casing with the burner operating | Pd (%)   |  | 0,2   |

| Gas supply pressures |             |      |      |
|----------------------|-------------|------|------|
| Gas                  |             | Pa   | mbar |
| Methane G20          | <b>Nom.</b> | 2000 | 20   |
|                      | <b>Min.</b> | 1700 | 17   |
|                      | <b>Max.</b> | 2500 | 25   |
| Propane G31          | <b>Nom.</b> | 3700 | 37   |
|                      | <b>Min.</b> | 2500 | 25   |
|                      | <b>Max.</b> | 4500 | 45   |

| Gas rate maximum - central heating    |      |      |
|---------------------------------------|------|------|
| Methane G20                           | m³/h | 2,75 |
| Propane G31                           | kg/h | 2,02 |
| Gas rate maximum - domestic hot water |      |      |
| Methane G20                           | m³/h | 3,28 |
| Propane G31                           | kg/h | 2,41 |
| Gas rate minimum - ch dhw             |      |      |
| Methane G20                           | m³/h | 0,66 |
| Propane G31                           | kg/h | 0,47 |

| Heating                                     |     |         |
|---|-----|---------|
| Adjustable temperature *                    | °C  | 25 - 80 |
| Max. operating temp.                        | °C  | 90      |
| Maximum pressure                            | kPa | 300     |
|   | bar | 3,0     |
| Minimum pressure                            | kPa | 30      |
|   | bar | 0,3     |
| Available pressure difference (at 1000 l/h) | kPa | 45,0    |
|   | bar | 0,450   |

\* At minimum useful power

| Domestic hot water                             |       |         |
|--|-------|---------|
| Temp. Minimum-Maximum                          | °C    | 35 - 55 |
| Maximum pressure                               | kPa   | 1000    |
|  | bar   | 10      |
| Minimum pressure                               | kPa   | 30      |
|  | bar   | 0,3     |
| Maximum flow rate<br>( $\Delta T=25$ K)        | l/min | 17,7    |
|  | l/min | 12,3    |
| Minimum flow rate                              | l/min | 2,5     |
|  | l/min | 14,8    |
| Specific d.h.w. flow rate ( $\Delta T=30$ K) * | l/min | 14,8    |

\* Reference standard EN 625

| Chimney design #                      |      |        |
|---------------------------------------|------|--------|
| Max. flue gas temperature at 60°/80°C | °C   | 78     |
| Max. flue gas temperature at 30°/50°C | °C   | 44     |
| Max. flue gas mass flow rate          | kg/s | 0,0144 |
| Min. flue gas mass flow rate          | kg/s | 0,0016 |
| Max. air mass flow rate               | kg/s | 0,0139 |
| Min. air mass flow rate               | kg/s | 0,0015 |

# Values refer to tests with 80 mm 1 + 1 twin pipe discharge Methane gas G20 and heat input in d.h.w. mode

# TECHNICAL SPECIFICATIONS

| Electrical data              |       |     |
|------------------------------|-------|-----|
| Voltage                      | V     | 230 |
| Frequency                    | Hz    | 50  |
| Output at nominal heat input | W     | 106 |
| Output in stand-by           | W     | 3   |
| Degree of protection         | IPX5D |     |

| Other characteristics    |                 |     |
|--------------------------|-----------------|-----|
| Height                   | mm              | 700 |
| Width                    | mm              | 400 |
| Depth                    | mm              | 268 |
| Weight                   | kg              | 36  |
| Water content in boiler  | dm <sup>3</sup> | 2   |
| Min. ambient temperature | °C              | -5  |
| Max. ambient temperature | °C              | 40  |

| Flue gas discharges                 |    |        |
|-------------------------------------|----|--------|
| Boiler type                         |    |        |
| B23P C13 C33 C43 C53 C63 C83 C93    |    |        |
| Coaxial air/flue gas duct Ø         | mm | 60/100 |
| Twin pipe air/flue gas duct Ø       | mm | 80/80  |
| Coaxial air/flue gas duct to roof Ø | mm | 80/125 |

G20 Hi. 34.02 MJ/m<sup>3</sup> (15°C, 1013.25 mbar)

G31 Hi. 46.34 MJ/kg (15°C, 1013.25 mbar)

1 mbar corresponds to approx. 10 mm H<sub>2</sub>O

(2856)

# TECHNICAL SPECIFICATIONS

|   |                       |
|---|-----------------------|
| Model(s):                                     | <b>M375CB.2530 SM</b> |
| Condensing boiler:                            | Si                    |
| Low-temperature boiler (**):                  | No                    |
| B1 boiler:                                    | No                    |
| Cogeneration space heater:                    | No                    |
| If yes, equipped with a supplementary heater: | -                     |
| Combination heater:                           | Si                    |

| Item  | Symbol      | Value     | Unit      | Item   | Symbol     | Value     | Unit     |
|---|-------------|-----------|-----------|--|------------|-----------|----------|
| <b>Rated heat output</b>  | $P_{rated}$ | <b>26</b> | <b>kW</b> | <b>Seasonal space heating energy efficiency</b>                            | $\eta_s$   | <b>94</b> | <b>%</b> |
|   |             |           |           | Seasonal energy efficiency class   |            | <b>A</b>  |          |
| For boiler space heaters and boiler combination heaters: Useful heat output |             |           |           | For boiler space heaters and boiler combination heaters: Useful efficiency |            |           |          |
| At rated heat output and high-temperature regime (*)                        | $P_4$       | 25,7      | kW        | At rated heat output and high-temperature regime (*)                       | $\eta_4$   | 88,9      | %        |
| At 30% of rated heat output and low-temperature regime (**)                 | $P_1$       | 8,6       | kW        | At 30% of rated heat output and low-temperature regime (**)                | $\eta_1$   | 98,7      | %        |
| Auxiliary electricity consumption   |             |           |           | Other items  |            |           |          |
| At full load  | $el_{max}$  | 0,036     | kW        | Standby heat loss  | $P_{siby}$ | 0,110     | kW       |
| At part load  | $el_{min}$  | 0,011     | kW        | Ignition burner power consumption  | $P_{ign}$  | -         | kW       |
| In standby mode   | $P_{SB}$    | 0,003     | kW        | Annual energy consumption  | $Q_{HE}$   | 79        | GJ       |
|   |             |           |           | Sound power level, indoors   | $L_{WA}$   | 50        | dB       |
|   |             |           |           | Emission of nitrogen oxides  | $NO_x$     | 35        | mg/kWh   |

For combination heaters:

|                                |            |       |     |  |             |        |     |
|--------------------------------|------------|-------|-----|--|-------------|--------|-----|
| <b>Declared load profile</b>   | XL         |       |     | <b>Water heating energy efficiency</b> | $\eta_{wh}$ | 84     | %   |
| Daily electricity consumption  | $Q_{elec}$ | 0,167 | kWh | Daily fuel consumption                 | $Q_{fuel}$  | 23,199 | kWh |
| Annual electricity consumption | AEC        | 37    | kWh | Annual fuel consumption                | AFC         | 18     | GJ  |

Contact details

See manual cover

(\*) High-temperature regime means 60°C return temperature at heater inlet and 80°C feed temperature at heater outlet.

(\*\*) Low temperature means for condensing boilers 30°C, for low-temperature boilers 37°C and for other heaters 50°C return temperature (at heater inlet).

**INSTALLERS**

# TECHNICAL SPECIFICATIONS

## 4.6 Technical data M375CB.3035 SM

|  |        |       |
|--|--------|-------|
| (nom.Q.) Nominal heat input in heating mode (Hi)                       | kW     | 31,0  |
|  | kcal/h | 26655 |
| (nom.Q.) Nominal heat input in heating mode (Hi) with 20% H2NG mixture | kW     | 27,1  |
|  | kcal/h | 23302 |
| (nom.Q.) Nominal heat input in d.h.w. mode (Hi)                        | kW     | 34,9  |
|  | kcal/h | 30009 |
| (nom.Q.) Nominal heat input in DHW mode (Hi) with 20% H2NG mixture     | kW     | 31,3  |
|  | kcal/h | 26913 |
| (nom.Q.) Minimum heat input (Hi)                                       | kW     | 7,0   |
|  | kcal/h | 6019  |
| * Max. heat output in heating mode 60°/80°C                            | kW     | 30,5  |
|  | kcal/h | 26225 |
| * Max. heat output in d.h.w. mode 60°/80°C                             | kW     | 34,3  |
|  | kcal/h | 29493 |
| * Min. heat output 60°/80°C  | kW     | 6,6   |
|  | kcal/h | 5675  |
| ** Max. heat output in heating mode 30°/50°C                           | kW     | 33    |
|  | kcal/h | 28375 |
| ** Max. heat output in d.h.w. mode 30°/50°C                            | kW     | 37,2  |
|  | kcal/h | 31986 |
| ** Min. heat output 30°/50°C   | kW     | 7,3   |
|  | kcal/h | 6277  |

| Data in heating mode                      |        |            |
|---|--------|------------|
| NOx class                                 |        | 6          |
| Weighted NOx ***                          | mg/kWh | 33         |
|   | ppm    | 19         |
| CO at nom. Q. (0% O2) ***                 | ppm    | 190,0      |
| CO at nom. Q. (0% O2) ***                 | ppm    | 9,0        |
| CO2 at nom. Q. with G20                   | %      | 8,5 - 9,5  |
| CO2 at min. Q. with G20                   | %      | 8,5 - 9,5  |
| CO2 at nom. Q. with G31                   | %      | 9,5 - 10,5 |
| CO2 at min. Q. with G31                   | %      | 9,5 - 10,5 |
| ** Condensate quantity at nom.Q. 30°/50°C | l/h    | 5,6        |
| ** Condensate quantity at min.Q. 30°/50°C | l/h    | 1,0        |
| Condensate pH                             | pH     | 4,0        |

| Data in d.h.w. mode     |   |            |
|-------------------------|---|------------|
| CO2 at nom. Q. with G20 | % | 8,5 - 9,5  |
| CO2 at min. Q. with G20 | % | 8,5 - 9,5  |
| CO2 at nom. Q. with G31 | % | 9,5 - 10,5 |
| CO2 at min. Q. with G31 | % | 9,5 - 10,5 |
| O2 at nom. Q. with G20  | % | 4,2 + 6,6  |
| O2 at min. Q. with G20  | % | 4,2 + 6,6  |

\* With return water temperature that does not permit condensation

\*\* With return water temperature that does permits condensation

\*\*\* With coax. flue gas discharge 60/100 0.9 m and METHANE gas G20

# TECHNICAL SPECIFICATIONS

| Measured efficiency in heating mode  |          |  |       |
|--|----------|--|-------|
| * Nominal efficiency 60°/80°C  | %        |  | 98,3  |
| * Min. efficiency 60°/80 C   | %        |  | 95,0  |
| ** Nominal efficiency 30°/50°C   | %        |  | 106,5 |
| ** Min. efficiency 30°/50°C  | %        |  | 105,5 |
| ** Efficiency At 30 % of load  | %        |  | 109,7 |
| Heat loss at the chimney with burner operating                                 | Pf (%)   |  | 1,5   |
| Heat loss at the chimney with burner off $\Delta T$ 50°C                       | Pfbs (%) |  | 0,2   |
| Heat loss towards the environment through the casing with the burner operating | Pd (%)   |  | 0,2   |

| Gas supply pressures |             |      |      |
|----------------------|-------------|------|------|
| Gas                  |             | Pa   | mbar |
| Methane G20          | <b>Nom.</b> | 2000 | 20   |
|                      | <b>Min.</b> | 1700 | 17   |
|                      | <b>Max.</b> | 2500 | 25   |
| Propane G31          | <b>Nom.</b> | 3700 | 37   |
|                      | <b>Min.</b> | 2500 | 25   |
|                      | <b>Max.</b> | 4500 | 45   |

| Gas rate maximum - central heating    |      |      |
|---------------------------------------|------|------|
| Methane G20                           | m³/h | 3,28 |
| Propane G31                           | kg/h | 2,41 |
| Gas rate maximum - domestic hot water |      |      |
| Methane G20                           | m³/h | 3,69 |
| Propane G31                           | kg/h | 2,71 |
| Gas rate minimum - ch dhw             |      |      |
| Methane G20                           | m³/h | 0,36 |
| Propane G31                           | kg/h | 0,26 |

| Heating                                     |     |         |
|---|-----|---------|
| Adjustable temperature *                    | °C  | 25 - 80 |
| Max. operating temp.                        | °C  | 90      |
| Maximum pressure                            | kPa | 300     |
|   | bar | 3,0     |
| Minimum pressure                            | kPa | 30      |
|   | bar | 0,3     |
| Available pressure difference (at 1000 l/h) | kPa | 45,0    |
|   | bar | 0,450   |

\* At minimum useful power

| Domestic hot water                             |       |         |
|--|-------|---------|
| Temp. Minimum-Maximum                          | °C    | 35 - 55 |
| Maximum pressure                               | kPa   | 1000    |
|  | bar   | 10      |
| Minimum pressure                               | kPa   | 30      |
|  | bar   | 0,3     |
| Maximum flow rate<br>( $\Delta T=25$ K)        | l/min | 19,7    |
|  | l/min | 13,8    |
| Minimum flow rate                              | l/min | 2,5     |
| Specific d.h.w. flow rate ( $\Delta T=30$ K) * | l/min | 16,4    |

\* Reference standard EN 625

| Chimney design #                      |      |        |
|---------------------------------------|------|--------|
| Max. flue gas temperature at 60°/80°C | °C   | 80     |
| Max. flue gas temperature at 30°/50°C | °C   | 46     |
| Max. flue gas mass flow rate          | kg/s | 0,0162 |
| Min. flue gas mass flow rate          | kg/s | 0,0032 |
| Max. air mass flow rate               | kg/s | 0,0156 |
| Min. air mass flow rate               | kg/s | 0,0031 |

# Values refer to tests with 80 mm 1 + 1 twin pipe discharge Methane gas G20 and heat input in d.h.w. mode

# TECHNICAL SPECIFICATIONS

| Electrical data              |       |     |
|------------------------------|-------|-----|
| Voltage                      | V     | 230 |
| Frequency                    | Hz    | 50  |
| Output at nominal heat input | W     | 120 |
| Output in stand-by           | W     | 3   |
| Degree of protection         | IPX5D |     |

| Other characteristics    |                 |     |
|--------------------------|-----------------|-----|
| Height                   | mm              | 700 |
| Width                    | mm              | 400 |
| Depth                    | mm              | 268 |
| Weight                   | kg              | 36  |
| Water content in boiler  | dm <sup>3</sup> | 2   |
| Min. ambient temperature | °C              | -5  |
| Max. ambient temperature | °C              | 40  |

| Flue gas discharges                 |    |        |
|-------------------------------------|----|--------|
| Boiler type                         |    |        |
| B23P C13 C33 C43 C53 C63 C83 C93    |    |        |
| Coaxial air/flue gas duct Ø         | mm | 60/100 |
| Twin pipe air/flue gas duct Ø       | mm | 80/80  |
| Coaxial air/flue gas duct to roof Ø | mm | 80/125 |

G20 Hi. 34.02 MJ/m<sup>3</sup> (15°C, 1013.25 mbar)

G31 Hi. 46.34 MJ/kg (15°C, 1013.25 mbar)

1 mbar corresponds to approx. 10 mm H<sub>2</sub>O

(2857)

# TECHNICAL SPECIFICATIONS

|   |                       |
|---|-----------------------|
| Model(s):                                     | <b>M375CB.3035 SM</b> |
| Condensing boiler:                            | Si                    |
| Low-temperature boiler (**):                  | No                    |
| B1 boiler:                                    | No                    |
| Cogeneration space heater:                    | No                    |
| If yes, equipped with a supplementary heater: | -                     |
| Combination heater:                           | Si                    |

| Item                     | Symbol      | Value     | Unit      | Item  | Symbol   | Value     | Unit     |
|--------------------------|-------------|-----------|-----------|---|----------|-----------|----------|
| <b>Rated heat output</b> | $P_{rated}$ | <b>31</b> | <b>kW</b> | <b>Seasonal space heating energy efficiency</b> | $\eta_s$ | <b>94</b> | <b>%</b> |

|   |       |      |    |
|---|-------|------|----|
| For boiler space heaters and boiler combination heaters: Useful heat output |       |      |    |
| At rated heat output and high-temperature regime (*)                        | $P_4$ | 30,5 | kW |
| At 30% of rated heat output and low-temperature regime (**)                 | $P_1$ | 10,2 | kW |

|                                   |            |       |    |
|-----------------------------------|------------|-------|----|
| Auxiliary electricity consumption |            |       |    |
| At full load                      | $el_{max}$ | 0,038 | kW |
| At part load                      | $el_{min}$ | 0,012 | kW |
| In standby mode                   | $P_{SB}$   | 0,003 | kW |

|  |           |       |        |
|--|-----------|-------|--------|
| For boiler space heaters and boiler combination heaters: Useful efficiency |           |       |        |
| At rated heat output and high-temperature regime (*)                       | $\eta_4$  | 88,5  | %      |
| At 30% of rated heat output and low-temperature regime (**)                | $\eta_1$  | 98,8  | %      |
| Other items  |           |       |        |
| Standby heat loss  | $P_{sby}$ | 0,110 | kW     |
| Ignition burner power consumption  | $P_{ign}$ | -     | kW     |
| Annual energy consumption  | $Q_{HE}$  | 93    | GJ     |
| Sound power level, indoors   | $L_{WA}$  | 50    | dB     |
| Emission of nitrogen oxides  | $NO_x$    | 33    | mg/kWh |

For combination heaters:

|                                |            |       |     |  |             |        |     |
|--------------------------------|------------|-------|-----|--|-------------|--------|-----|
| <b>Declared load profile</b>   | XXL        |       |     | <b>Water heating energy efficiency</b> | $\eta_{wh}$ | 85     | %   |
| Daily electricity consumption  | $Q_{elec}$ | 0,215 | kWh | Daily fuel consumption                 | $Q_{fuel}$  | 28,220 | kWh |
| Annual electricity consumption | AEC        | 37    | kWh | Annual fuel consumption                | AFC         | 22     | GJ  |

Contact details See manual cover

(\*) High-temperature regime means 60°C return temperature at heater inlet and 80°C feed temperature at heater outlet.

(\*\*) Low temperature means for condensing boilers 30°C, for low-temperature boilers 37°C and for other heaters 50°C return temperature (at heater inlet).

**INSTALLERS**

# TECHNICAL SPECIFICATIONS

## 4.7 Hydraulic characteristics

The hydraulic characteristics represent the pressure (head) available in the heating system based on the flow rate.

### Model M375CB.2025 SM

Head (bar)

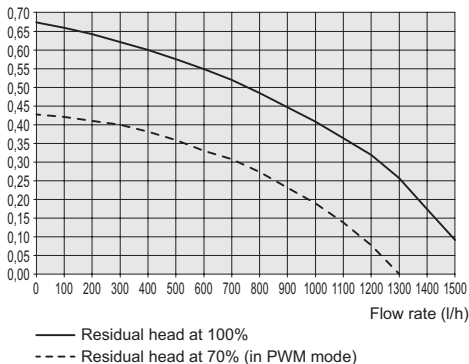

Figure 4.4

### Model M375CB.2530 SM - M375CB.3035 SM

Head (bar)

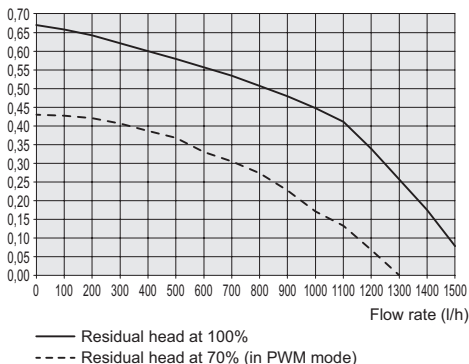

Figure 4.5

The load loss for the boiler has already been subtracted.

### Flow rate with the thermostatic cocks closed

The boiler has an automatic by-pass, which protects the primary condensate exchanger. If the circulation of water in the heating system decreases too much or totally stops due to the

closure of thermostatic valves or circuit cocks, the by-pass guarantees a minimum circulation of water inside the primary condensate exchanger.

The by-pass is calibrated for a differential pressure of approx. 0.3-0.4 bar.

## 4.8 Expansion tank

The difference in height between the safety valve and the highest point in the system can be max. 10 metres.

If differences are greater, increase the pre-load pressure of the expansion tank and the cold system by 0.1 bar for each 1 metre increase.

|                          |     |     |
|--------------------------|-----|-----|
| Total capacity           | l   | 7.0 |
| Pre-load pressure        | kPa | 100 |
|                          | bar | 1.0 |
| Useful capacity          | l   | 3.5 |
| Maximum system content * | l   | 109 |

Figure 4.6

\* In conditions of:

- Max. average system temperature of 85°C
- Initial temperature when filling the system 10°C.

**For systems with contents that exceed the maximum system content (indicated in the table), a supplementary expansion tank must be installed.**

# INSTALLATION

## 5 INSTALLATION

### 5.1 Warnings



**Protective gloves must be worn.**



**The appliance must be installed by a qualified installer in compliance with the applicable standards in force including.**



**The unit must discharge the combustion products directly outside or into a suitable exhaust flue designed for that purpose and in compliance with current national and local standards.**

**The unit is not suitable for receiving condensate from the combustion product evacuation system.**



**The combustion air must not contain chlorine, ammonia or alkaline agents.**

**Installing a boiler near to a swimming pool, washing machine or laundry room results in an aggressive mixture in the combustion air around the boiler.**

Before installation, it is **mandatory** to thoroughly wash all of the system pipes with non-aggressive chemical products. The purpose of this procedure is to remove any residues or impurities that could jeopardise good boiler operation.

After washing, the system must be treated.

The conventional warranty does not cover any problems resulting from failure to follow these instructions.

#### Check that:

- the boiler is suitable for the type of gas supplied (see adhesive label).

If it is necessary to convert the boiler to a different type of gas, see section "GAS CONVER-

SION" on page 64.

- the characteristics of the electric, water and gas supply networks comply with those on the plate.

The combustion products may only be discharged using the flue gas exhaust kits provided by the manufacturer, as they are an integral part of the boiler.

For LPG gas (Propane G31), the installation must also comply with the requirements of the distributing companies and with the requirements of current technical standards and laws.

The safety valve must be connected to a suitable discharge duct to avoid flooding if it is triggered.

The condensate outlet siphon must be connected to the residential condensate outlet duct; it must be possible to inspect it and it must be implemented in such a way as to avoid the condensate freezing (UNI 7129-5 and related standards).

The electric installation must comply with technical standards, in particular:

- It is **mandatory** to connect the boiler to an effective earthing system via a specific terminal.
- A multiway switch must be installed near the boiler for full disconnection in conditions of category III over-voltage. For information on the electrical connections, refer to section "Electrical connections" on page 46.
- **The electric conductors for connecting the remote control and external sensor to the boiler** must go through different channels than those for the mains voltage (230 V), as they are supplied with low safety voltage.



**If the power supply cable is damaged, it must only be replaced by a qualified technician.**

# INSTALLATION

## 5.2 Precautions for installation

**Follow these installation instructions:**

- Mount the boiler on a strong wall.
- Respect the measurements of the flue gas evacuation duct (provided in section “Flue gas outlet dimensions and lengths” on page 41) and the correct systems for installing the duct shown in the instruction sheet provided together with the flue gas evacuation pipe kit.
- Leave the minimum distances indicated in Figure 5.1 around the unit.

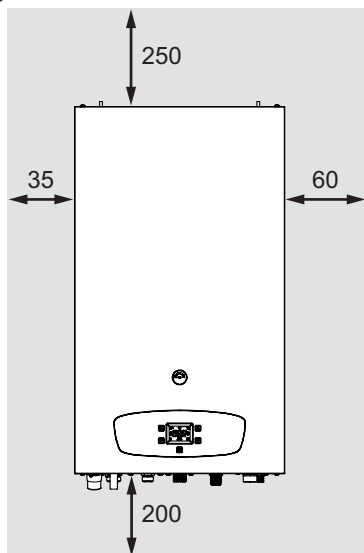

All measurements are in mm

Figure 5.1

- Leave 5 cm clearance in front of the boiler, if it is positioned in a cabinet, shelter or niche.
- In the case of an old heating system, before installing the boiler, carefully clean it in order to remove any sludgy deposits that have formed over time.
- We recommended installing a purification filter in the system or using a product that conditions the circulating water.

This latter solution, in particular, not only

cleans the system but also provides anti-corrosion protection by forming a protective film on the metal surfaces and neutralising the gases in the water.

**Filling the central heating system:**

- If the boiler is installed in rooms where the ambient temperature could fall below 0°C, take the necessary precautions to prevent damage to the boiler.
- Do not add antifreeze or anticorrosion products to the heating water in the wrong concentrations or use those with chemical/physical characteristics that are incompatible with the boiler’s hydraulic components.

The manufacturer does not assume any liability for this type of damage.

**Inform the user about the boiler’s anti-freeze function and any chemical products added to the heating system.**

## 5.3 Installing the boiler bracket

The boiler is provided with a bracket for assembly.

A paper template that contains all the measurements and information for correctly installing the support is provided.

The hydraulic and gas system must terminate with female fittings, 3/4" for the gas fitting and for the heating delivery and return, and 1/2" for the DHW inlet and outlet, or with welded copper pipes with  $\varnothing$  18 mm and  $\varnothing$  14 mm, respectively.

For measurements and useful data see section “Dimensions” on page 39, “Fittings” page 39, “Flue gas outlet dimensions and lengths” page 41.

# INSTALLATION

## 5.4 Dimensions

The boiler complies with the following dimensions:

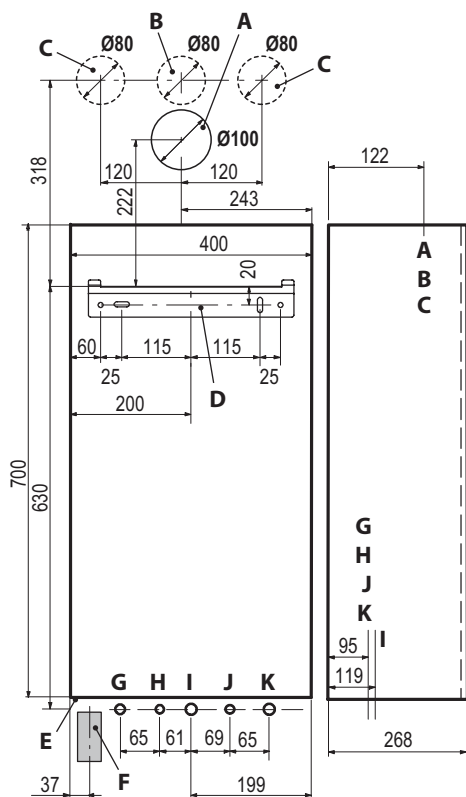

Figure 5.2

- A** Flue gas exhaust / air suction (coaxial  $\varnothing$  100/60)
- B** Flue gas exhaust ( $\varnothing$  80 twin pipe)
- C** Air suction ( $\varnothing$  80 twin pipe)
- D** Boiler mounting bracket
- E** Area for positioning the electric connection channels
- F** Area for positioning the condensate outlet pipe
- G** MR – Heating delivery
- H** US – DHW outlet
- I** Gas
- J** ES – DHW inlet
- K** RR – Heating return

## 5.5 Fittings

The boiler uses the following fittings:

|     | Cock     | Pipe $\varnothing$  |
|-----|----------|---------------------|
| MR  |          | $\varnothing$ 16/18 |
| US  |          | $\varnothing$ 12/14 |
| Gas | G 3/4 MF | $\varnothing$ 16/18 |
| ES  | G 1/2 MF | $\varnothing$ 12/14 |
| RR  |          | $\varnothing$ 16/18 |

G1/2F 3 bar safety valve fitting

Condensate discharge to be implemented with pipe min.  $\varnothing$  30 mm

## 5.6 Boiler assembly

- Remove the protective caps from the boiler pipes.
- Hook the boiler onto the bracket.
- Screw the cock on the boiler.
- Fix or weld the flared stub pipes, respectively  $\varnothing$  14 mm for the DHW inlet and outlet, and  $\varnothing$  18 mm for the hydraulic system return, delivery and gas.

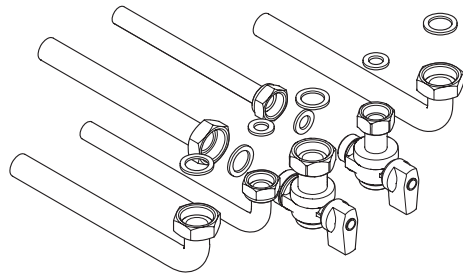

Figure 5.3

- Install a shut-off cock on the DHW inlet. The purpose of the cock is to hydraulically isolate the unit, making normal maintenance possible.
- If the hydraulic heating system is higher than the boiler surface, cocks should be installed in order to disconnect the system for maintenance purposes.
- Block the pipes by placing 1/2" and 3/4" gas-kets between the boiler fittings.

# INSTALLATION

- Carry out a leakage test for the gas supply system.
- Connect the safety valve discharge 4 (Figure 5.4) to an outlet funnel.

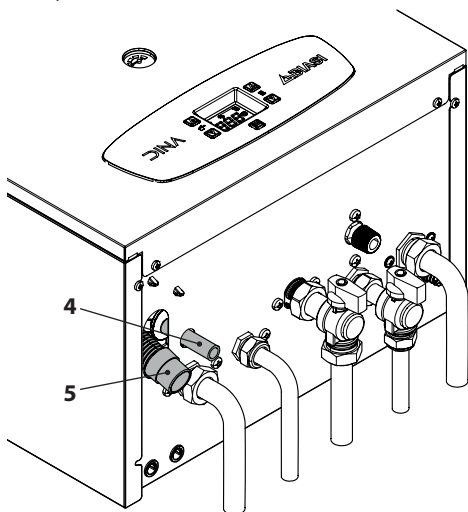

Figure 5.4

- Insert the flexible condensate discharge pipe 5 (Figure 5.4) inside the residential condensate discharge duct or the discharge funnel of the safety valve if the discharge is suitable for receiving acid condensate.

## 5.7 Installing the flue gas exhaust duct

Consult the sheet provided together with the preselected kit for information on how to correctly install the flue gas duct.

The horizontal sections of the flue gas pipes must have a slope of approx. 1.5 degrees (25 mm per metre), therefore the terminal must be higher than the boiler side opening.

Only the coaxial pipe with the terminal must be horizontal as the discharge pipe has already been implemented with the correct slope.

### CORRECT implementation of a wall-mounted concentric discharge system

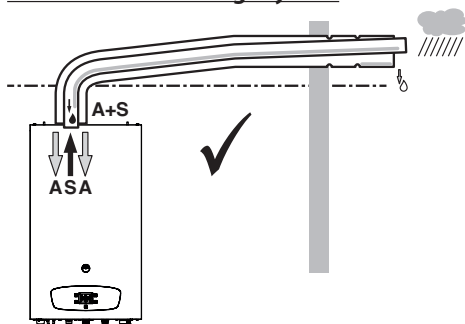

Figure 5.5

A = air suction  
S = flue gas outlet

### CORRECT implementation of twin flue gas outlet/air suction systems

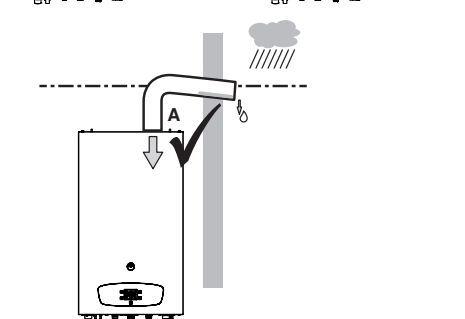
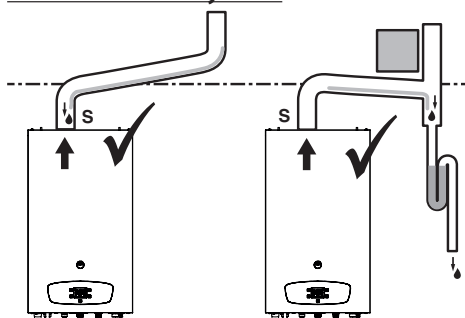

Figure 5.6

A = air suction  
S = flue gas outlet

# INSTALLATION

## INCORRECT implementation of twin flue gas outlet/air suction systems

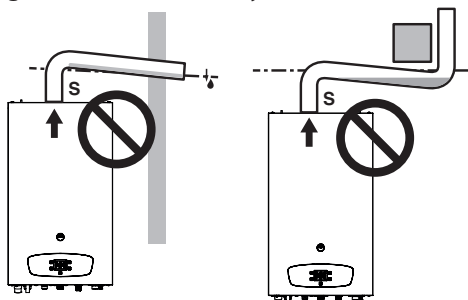
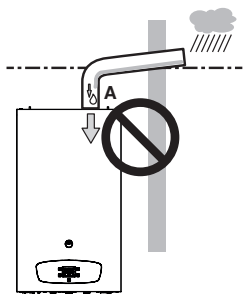

Figure 5.7

A = air suction

S = flue gas outlet



## 5.8 Flue gas outlet dimensions and lengths

The flue gas outlet/air suction can be set up in the following ways:

C13 C33 C43 C53 C63 C83 C93 B23P

Consult the sheet provided with the selected kit which is packaged separately.

The horizontal sections of the flue gas pipes must have a slope of approx. 1.5 degrees (25 mm per metre).



**The terminal must be higher than the boiler side opening.**

Only the coaxial pipe with the terminal must be horizontal as the discharge pipe has already been implemented with the correct slope.

The following kits are available for connection to the boiler:

### Wall-mounted flue gas outlet kit (Figure 5.8 A)

| Coaxial duct Ø 60/100 (A) - TYPE C13 |         |
|--------------------------------------|---------|
| Nominal length                       | 0.915 m |
| Minimum length                       | 0.5 m   |
| Maximum length                       | 10 m    |

C13

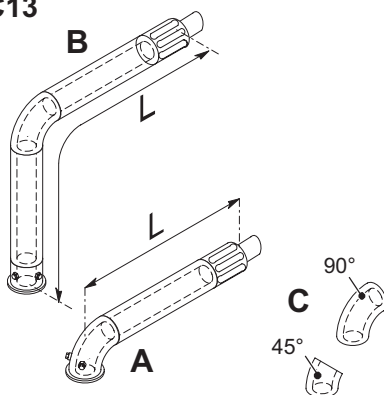

Figure 5.8

### Vertical flue gas outlet kit with 90° elbow (Figure 5.8 B)

This kit is used to raise the outlet axis of the boiler by 635 mm.

The terminal must always discharge horizontally.

| Coaxial duct Ø 60/100 with 90° elbow (B) - TYPE C13 |        |
|---|--------|
| Nominal length                                      | 1.55 m |
| Minimum length                                      | 0.5 m  |
| Maximum length                                      | 10 m   |

### Supplementary 45° or 90° elbows (Figure 5.8 C)

Coaxial elbows Ø 60/100 mm.

When these elbows are used in the duct, they reduce the maximum length of the flue gas duct by:

# INSTALLATION

|                      |       |
|----------------------|-------|
| For a 45° elbow loss | 0.5 m |
| For a 90° elbow loss | 1 m   |

## Twin pipe suction discharge duct kit Ø 80 mm - (Figure 5.9) - (Figure 5.10)

This kit is used to separate the flue gas outlet from the air suction. The terminals can be inserted in exhaust flues designed for this purpose, or discharge flue gas or intake air directly on the wall.

| Twin ducts Ø 80 - TYPE C13 - C43 - C53 - C83 - C93 |       |
|--|-------|
| Minimum length                                     | 0.5 m |
| Maximum length                                     | 40 m  |

**N.B.:** The terminals of the air suction and flue gas exhaust pipes must not be positioned on opposite walls of the building (EN 483).

INSTALLERS

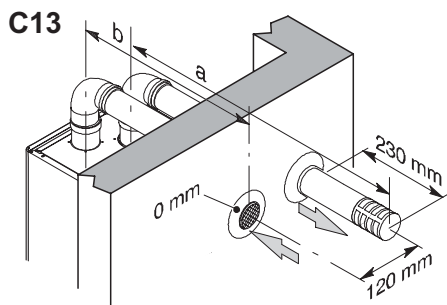

Figure 5.9

90° and 45° elbows with Ø 80 mm are also available which reduce the total max. length of the ducts:

|                      |        |
|----------------------|--------|
| For a 45° elbow loss | 0.9 m  |
| For a 90° elbow loss | 1.65 m |

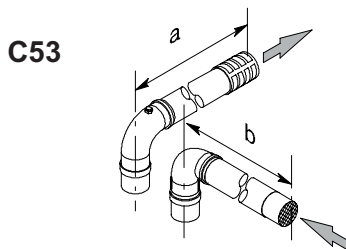
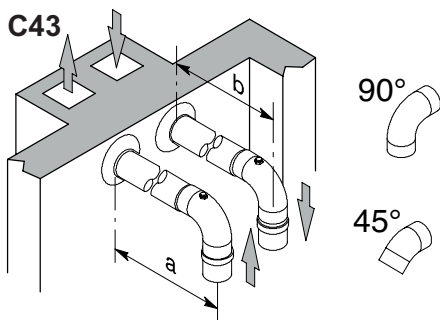

Figure 5.10

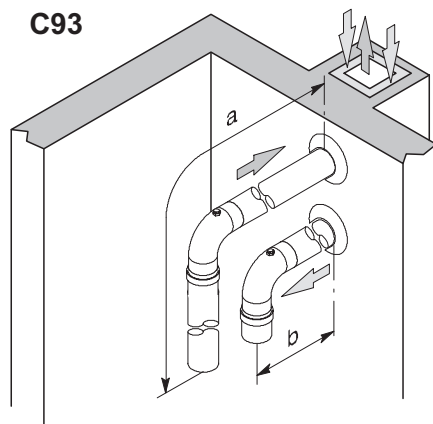

Figure 5.11

## TYPE C63

If using ducts and terminals from another manufacturer (type C63), these must be approved and, in the case of a flue gas duct, materials must be used that comply with the condensation products.

When dimensioning the ducts, take into ac-

# INSTALLATION

count the residual head at the fan:

|  |              |     |    |
|--|--------------|-----|----|
| Useful static pressure at nominal heat input                 | <b>25 kW</b> | 120 | Pa |
|  | <b>30 kW</b> | 150 | Pa |
|  | <b>35 kW</b> | 180 | Pa |
| Overheated flue  | <b>25 kW</b> | 92  | °C |
|  | <b>30 kW</b> | 94  | °C |
|  | <b>35 kW</b> | 96  | °C |
| Maximum recirculation of CO <sub>2</sub> in the suction duct | <b>25 kW</b> | 1,2 | %  |
|  | <b>30 kW</b> | 1,4 | %  |
|  | <b>35 kW</b> | 1,4 | %  |

## TYPE C<sub>83</sub> (Figure 5.12)

The boiler with this type of outlet installed must take the comburent air from the outside and discharge the flue gas in the individual or collective chimney designed for this purpose.

### C83

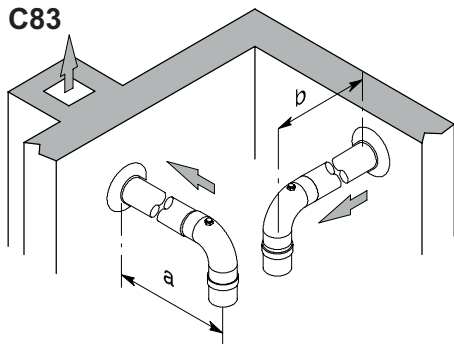

Figure 5.12

## Roof-mounted flue gas outlet kit (Figure 5.13)

This kit enables flue gases to be released directly through the roof.

| Coaxial duct Ø 80/125 - TYPE C33 |              |  |        |
|----------------------------------|--------------|--|--------|
| Nominal length                   |              |  | 0.96 m |
| Maximum length                   | <b>25 kW</b> |  | 15 m   |
|                                  | <b>30 kW</b> |  | 12 m   |
|                                  | <b>35 kW</b> |  | 12 m   |

### C33

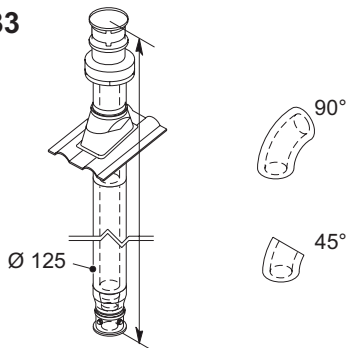

Figure 5.13

Extensions are available for reaching the maximum height.

Coaxial 90° and 45° elbows with Ø 80/125 mm are available that reduce the total maximum length of the ducts by:

|                      |       |
|----------------------|-------|
| For a 45° elbow loss | 0.5 m |
| For a 90° elbow loss | 1 m   |

## TYPE B<sub>23P</sub> (Figure 5.14)

This type of flue gas outlet extracts the necessary combustion air from the room the boiler is installed in; the combustion products must be released outside and the outlet pipe can be through the wall or a chimney.

### TYPE B<sub>23P</sub> duct

|                        |       |
|------------------------|-------|
| Minimum length         | 0.5 m |
| Maximum length (A + B) | 40 m  |



**There must be a suitable air vent in the room where the boiler is installed for the supply of combustion air and for room ventilation.**

For proper operation, the minimum necessary air exchange must be 2 m<sup>3</sup>/h for each kW of heat input.

# INSTALLATION

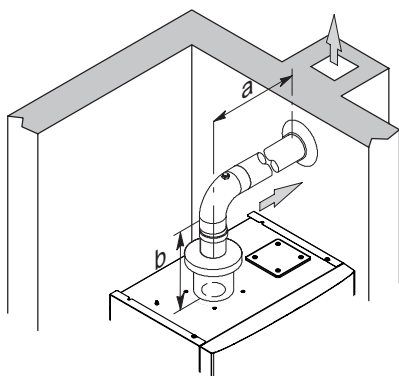

B<sub>23P</sub>

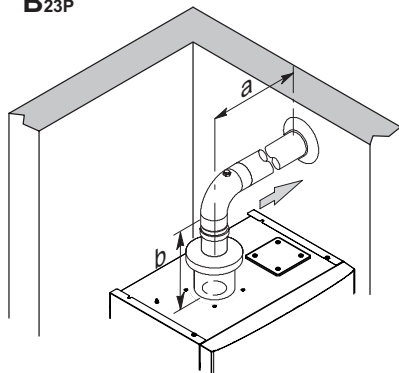

Figure 5.14

90° and 45° elbows with Ø 80 mm are also available which reduce the total max. length of the ducts:

|                      |        |
|----------------------|--------|
| For a 45° elbow loss | 0.9 m  |
| For a 90° elbow loss | 1.65 m |

## 5.9 C<sub>63</sub> exhaust-flue pipework

### Exhaust flue pipework with flue-gas kit in smooth propylene or smooth stainless steel

Kits are available in Ø80 mm, Ø60 mm or Ø50 mm for expelling flue gases (a), while the air suction kits (b) are always Ø80 mm.

When setting up any ducted system, the hollow cavity between the secondary flue, exhaust flue or ducted pipe and the internal wall

of the technical cabinet must only be used for this system exclusively.

All components must be made from materials with class A1 reaction to fire according to standard UNI EN 13501-1. **Note that extendible metal hoses must not be used.**

The flue must receive the flue gas output from the flue gas duct connected to the appliance only. Collective exhaust flues cannot be used and the output from extractor hoods above cooking appliances of any kind or output from other generators cannot be conveyed through the same flue or flue gas duct.

Therefore, if you install a ducted pipe for evacuating combustion products from any type of appliance inside an existing flue, this flue must then be used solely for the ducted pipe system. It cannot contain any other type of pipework (for example gas, heating or solar pipes), nor can it contain cables of any kind (electrical, TV antenna, etc.). However, if there is enough space, it can be used to install other ducted pipes hooked up to appliances powered by other fuels, as long as the minimum clearances required by the regulations are respected.



**A condensate siphon must also be installed at the base of the flue-gas kit. This is because the boiler is not built to collect condensate from the system for evacuating combustion products.**

| Twin C <sub>63</sub> |                |                |                |
|----------------------|----------------|----------------|----------------|
|                      | 80+80<br>(a+b) | 60+80<br>(a+b) | 50+80<br>(a+b) |
| <b>25 kW</b>         | 40.0           | 12.6           | 11.2           |
| <b>30 kW</b>         | 40.0           | 17.0           | 14.0           |
| <b>35 kW</b>         | 40.0           | 21.5           | 12.5           |

For every additional elbow, subtract 1.5 m from the total length.

For every tee connection, subtract 1.7 m from the total length.

For double-walled pipes in corrugated propyl-

# INSTALLATION

ene or corrugated stainless steel, reduce the effective length by 15%.



**The materials the pipes are made from must be suitable for use with this type of appliance.**

**The straight sections must not be deformed and must be suitably supported.**

**The joints must be sealed and protected against unthreading.**

**Insert the flue-gas draw stub kit above the boiler.**

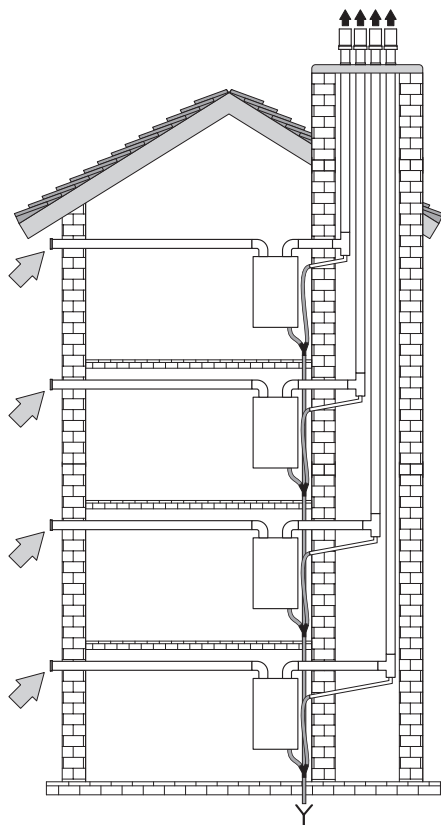

Figure 5.15

## 5.10 Positioning the draught terminals

The draught terminals must:

- be positioned on the outer perimeter walls of the building or on the roof;
- comply with the minimum distances Figure 5.16 and any national or local regulations.

| Position of the terminal  | mm        |
|---|-----------|
| <b>A</b> Under the window or other opening                                  | 600       |
| <b>B</b> Next to a window or door   | 400       |
| <b>B</b> Next to an air vent or ventilation opening                         | 600       |
| <b>C</b> Side of a balcony  | 1000      |
| <b>D</b> Under the gutter or discharge pipes                                | 300       |
| <b>E</b> Under the eaves  | 300       |
| <b>F</b> Under balconies  | 300       |
| <b>G</b> Under the garage roof  | <b>NO</b> |
| <b>H</b> From vertical discharge pipes                                      | 300       |
| <b>I</b> From inner corners   | 300       |
| <b>J</b> From external corners  | 300       |
| <b>K</b> From the ground or other floor surfaces                            | 2200      |
| <b>L</b> From a front facing surface without openings                       | 2000      |
| <b>M</b> From a front facing opening  | 3000      |
| <b>N</b> From an opening in the garage                                      | <b>NO</b> |
| <b>O</b> Between two vertical terminals in the same wall                    | 1500      |
| <b>P</b> Between two horizontal terminals in the same wall                  | 1000      |
| <b>Q</b> Above the pitch of a roof with a slope less than or equal to 30° * | 350       |
| <b>Q</b> Above the pitch of a roof with a slope greater than 30° *          | 600       |
| <b>R</b> Above a flat roof *  | 300       |
| <b>S</b> From a wall *  | 600       |
| <b>S</b> From two walls at an angle *                                       | 1000      |

\* Roof-mounted terminal

# INSTALLATION

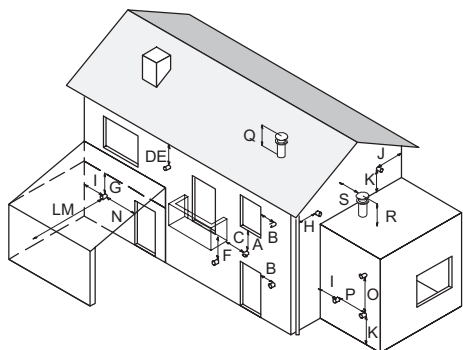

Figure 5.16

## 5.11 Electrical connections

- Unscrew the screws **L** (Figure 5.17) and remove the front panel **M** by pulling it towards you and then pushing it upwards in order to release it from the top fastenings Figure 5.18.

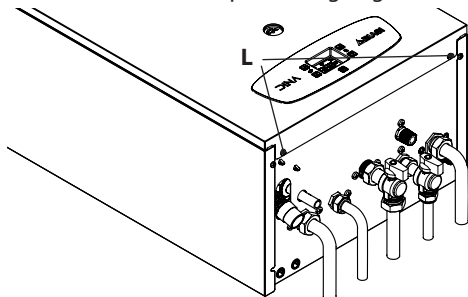

Figure 5.17

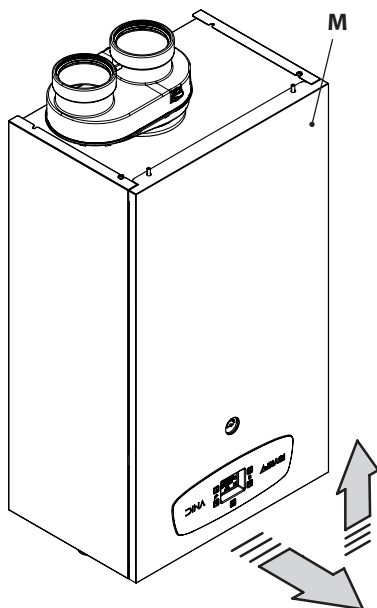

Figure 5.18

- Unscrew the screws **N** (Figure 5.19).

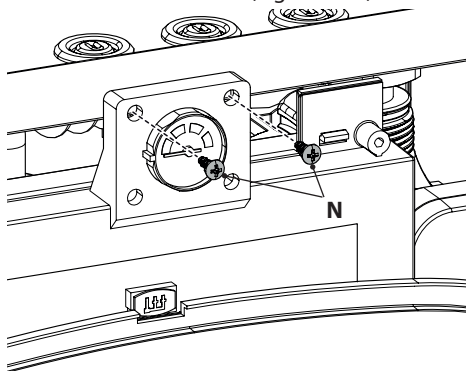

Figure 5.19

- Turn the control panel **O**, as shown in Figure 5.20.
- Unscrew the screw **P** and lift the cover **Q** to

# INSTALLATION

access the electric power supply terminal block, remote and external sensor (Figure 5.20).

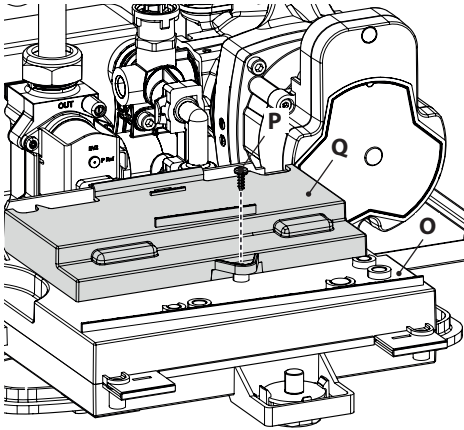

Figure 5.20

## Connecting to the electric power supply grid

- Connect the electric power supply cable to the multiway switch, respecting the correspondence of the power line (brown wire) and the neutral (blue wire) Figure 5.21.
- **Connect the earth wire (yellow/green) to an effective earthing system.**

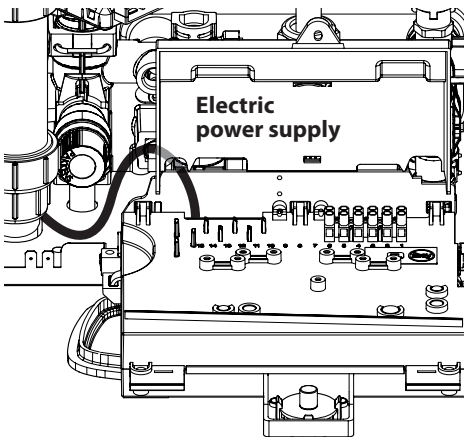

Figure 5.21



**The earth wire must be longer than the electric power wires.**

The electric power supply cable or wire for the unit (type: H03VV-F) must have a minimum cross section of 0.75 mm<sup>2</sup>, be kept away from hot or sharp parts and comply with current technical standards.

Make the boiler cable exit using specific cable glands **R** (Figure 5.24).

## 5.12 Connecting a room thermostat or zone valves

Use the terminals indicated in Figure 5.22 to connect the ambient thermostat.

**The installation of the ambient thermostat excludes the installation of the remote control. When connecting any type of ambient thermostat, the electric jumper between terminals "1 and 2" must be removed.**

The electric conductors for the ambient thermostat must be inserted between terminals "1 and 2" as shown in Figure 5.22.



**Do not connect live cables on the "1 and 2" terminals.**

**Voltage-free contacts for the Ambient Thermostat or Remote Control** External sensor

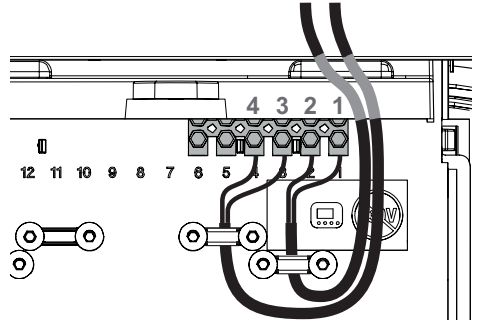

Figure 5.22

# INSTALLATION

The thermostat must have class II insulation (□) or be correctly connected to the earth.

Make the boiler cable exit using specific cable glands **R** (Figure 5.24).

## Connecting zone valves controlled by the room thermostat

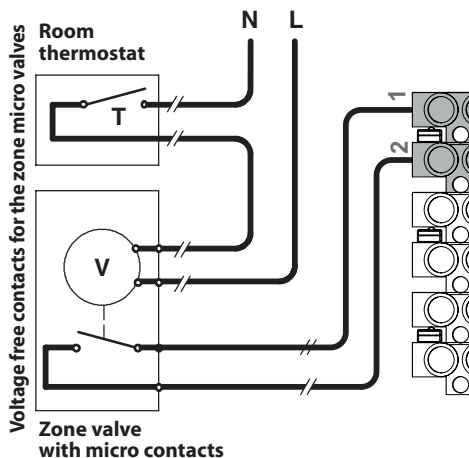

Use the room thermostat terminals indicated in Figure 5.22 to connect the zone valves. The electric conductors of the zone valve micro contacts must be inserted in the "1 and 2" terminals of the ambient thermostat terminal board as shown in Figure 5.23.

**The electric jumper between terminals "1 and 2" must be removed.**



**Do not connect live cables on the "1 and 2" terminals.**

The path of the ambient thermostat connection wires must follow the path indicated in Figure 5.22.

Make the boiler cables exit using specific cable glands **R** (Figure 5.24).

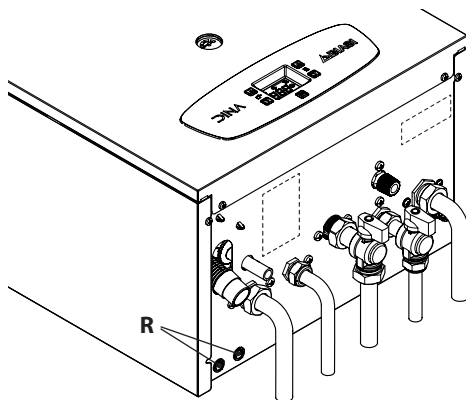

Figure 5.24

## 5.13 Installing the external temperature sensor (optional)

The external sensor must be installed on an external wall of the building avoiding:

- Direct radiation of the sun's rays.
- Damp walls or walls where mould forms.
- Installation near fans, drain outlets or chimneys.

## 5.14 Electric connection between the boiler and the external sensor

To connect the external sensor to the boiler, use electric cables with a cross section of no less than 0.50 mm<sup>2</sup>.

**The electrical conductors for connecting the external sensor to the boiler must go through different channels to those for the mains voltage (230 V), as they are supplied at a safe low voltage and cannot exceed 20 metres in length.**

Use the terminals indicated in Figure 5.22 to connect the external sensor.

The path of the external sensor connection wires must follow the path indicated in Figure 5.22.

# INSTALLATION

Make the boiler cables exit using specific cable glands **R** (Figure 5.24).

## 5.15 Selecting the type of external sensor

The boiler is set to operate without an external sensor.

If an external sensor (optional) **IS CONNECTED** to the boiler, the correct parameter must be set according to the type of probe installed.

### Sequence for setting the type of external sensor

- Enter “programming mode” by pressing the 14 and 16 buttons simultaneously for 5 seconds (Figure 5.25) until **HiS** (in reference to the “Boiler History” menu) appears on the LCD display (Figure 5.26).

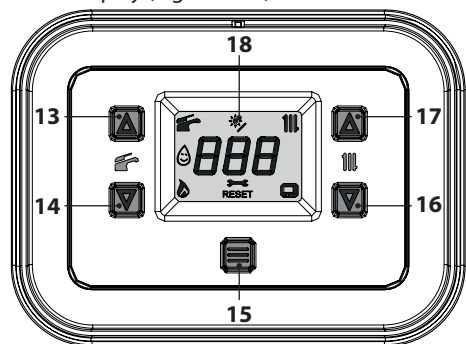

Figure 5.25

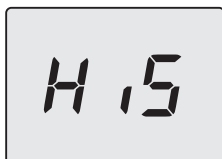

Figure 5.26

- Scroll through the menu using the 14 (back) or 16 (next) buttons until **PAr** (Figure 5.27) (in reference to the “Parameters” menu) appears on the LCD display.
- Press the 15 button for 1 second to enter the selected menu.



Figure 5.27

- Scroll through the various parameters by pressing the keys 14 (back) or 16 (forward), until **P57**, which alternates with the parameter value, appears on the LCD display (Figure 5.28).

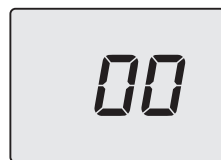

Figure 5.28

- Press the 15 button for 1 second (Figure 5.25) to open the selected parameter. The display will show the following (Figure 5.29).

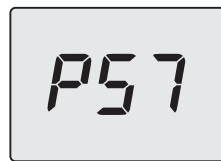

Figure 5.29

- Use keys 14 or 16 to modify the value of parameter 57 according to the type of probe installed (Figure 5.30).

# INSTALLATION

| PAR. | VALUE | DESCRIPTION                           |
|------|-------|---------------------------------------|
| P57  | 00    | Sensor not present (factory settings) |
|      | 01    | External sensor with 12 kOhm NTC      |
|      | 02    | External sensor with 10 kOhm NTC      |

Figure 5.30

- Press button 15 (Figure 5.25) to confirm the value entered. The display will show the following (Figure 5.31) for 5 seconds, then move up to the next level.



Figure 5.31

- Press the keys 14 and 16 simultaneously (Figure 5.25) to exit the level without changing the value (return to the previous level).

To exit the parameters menu:

- wait 15 minutes without pressing any key;
- switch off the electric power supply;
- press the 14 and 16 keys simultaneously for 5 seconds (Figure 5.25) (return to previous level).

## 5.16 Electrical connection of the remote (optional)

Use the terminals indicated in Figure 5.22 to connect the remote.

To connect the remote control to the boiler, refer also to the REMOTE CONTROL manual.

**The electric jumper between “1 and 2” must be removed.**

The path of the remote control cable must follow the path indicated in Figure 5.22.

Make the boiler cables exit using specific cable glands **R** (Figure 5.24).

## 5.17 Enabling operation with the external sensor and setting the K coefficient

The boiler is set with a K coefficient of zero for operation without the probe connected.

If the remote control **IS CONNECTED** to the boiler (optional), refer to Figure 5.32.

In this case, the K coefficient must be set remotely.

**Delivery temperature °C**

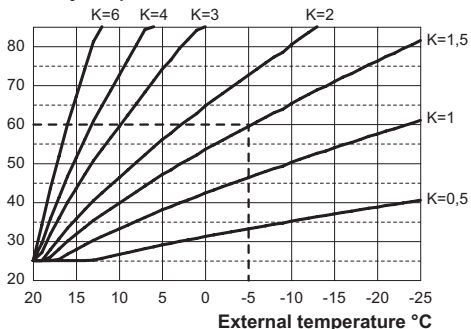

Figure 5.32

The K coefficient is a parameter that increases or decreases the boiler delivery temperature as the outdoor temperature varies.

When installing the external sensor, this parameter must be set based on the efficiency of the heating system to optimise the delivery temperature (Figure 5.32).

E.g. To achieve a heating system delivery temperature of 60°C with an outdoor temperature of -5°C, set a K of 1.5 (dashed line in Figure 5.32).

### Sequence for setting the K coefficient

- Enter “programming mode” by pressing the 14 and 16 buttons simultaneously for 5 seconds (Figure 5.33) until **HiS** (in reference to the “Boiler History” menu) appears on the LCD display (Figure 5.34).

# INSTALLATION

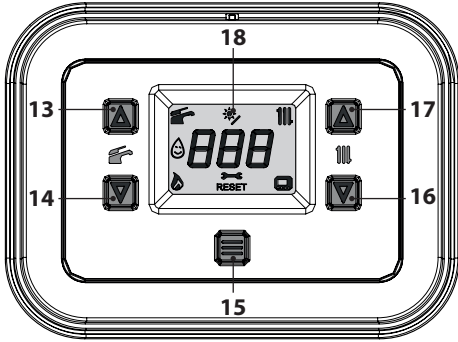

Figure 5.33



Figure 5.34

- Scroll through the menus using the 14 (back) or 16 (next) buttons until **PAr** (Figure 5.35) (in reference to the “Parameters” menu) appears on the LCD display.
- Press the 15 button for 1 second to enter the selected menu.



Figure 5.35

- Scroll through the various parameters by pressing the keys 14 (back) or 16 (forward), until **P14**, which alternates with the parameter value, appears on the LCD display (Figure 5.36).



Figure 5.36

- Press the 15 button for 1 second (Figure 5.33) to open the selected parameter. The display will show the following (Figure 5.37).

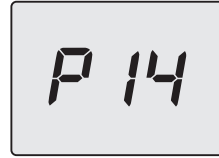
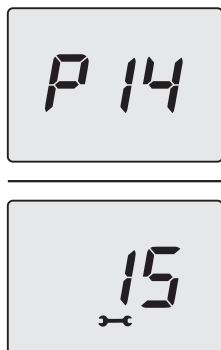

Figure 5.37

- Pressing the 14 or 16 keys, it is possible to change the value of parameter 14 from a minimum of **00** to a maximum of **60** based on the selected curve of the K coefficient in Figure 5.32 (the value shown on the display, in Figure 5.38, corresponds to **K = 1.5**).



**Figure 5.38**

- Press button 15 (Figure 5.33) to confirm the value entered. The display will show the following (Figure 5.39) for 5 seconds, then move up to the next level.



**Figure 5.39**

- Press the keys 14 and 16 simultaneously (Figure 5.33) to exit the level without changing the value (return to the previous level).

To exit the parameters menu:

- wait 15 minutes without pressing any key;
- switch off the electric power supply;
- press the 14 and 16 keys simultaneously for 5 seconds (Figure 5.33) (return to previous level).

The system delivery temperature will follow the trend in relation to the set K coefficient. If the room temperature is not comfortable, increase or decrease the heating system delivery temperature by  $\pm 15^\circ\text{C}$  using the 16 (decrease) and 17 (increase) buttons (Figure 5.33).

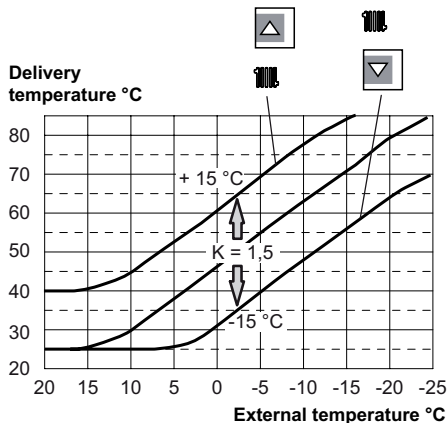

**Figure 5.40**

The temperature trend when changing the setting using keys 16 and 17 for a K 1.5 is shown in Figure 5.40.

## 5.18 Setting pump post-circulation

The pump, in heating mode, is set for a post-circulation of about one minute at the end of each heat request.

This time can be changed from a minimum of 10 seconds to a maximum of 20 minutes in programming mode, using either the control panel or the remote.

- Enter “programming mode” by pressing the 14 and 16 buttons simultaneously for 5 seconds (Figure 5.41) until **HiS** (in reference to the “Boiler History” menu) appears on the LCD display (Figure 5.42).

## INSTALLATION

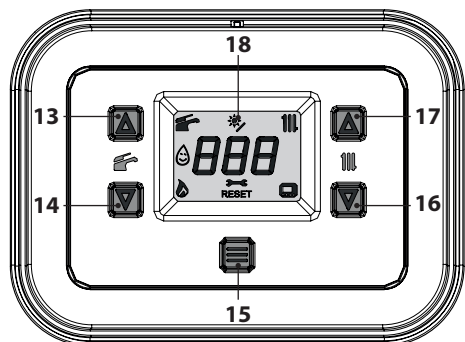

Figure 5.41

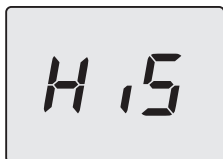

Figure 5.42

- Scroll through the menu using the 14 (back) or 16 (next) buttons until **PAr** (Figure 5.43) (in reference to the “Parameters” menu) appears on the LCD display.
- Press the 15 button for 1 second to enter the selected menu.



Figure 5.43

- Scroll through the various parameters by pressing the keys 14 (back) or 16 (forward), until **P12**, which alternates with the parameter value, appears on the LCD display (Figure 5.44).



Figure 5.44

- Press the 15 button for 1 second (Figure 5.41) to open the selected parameter. The display will show the following (Figure 5.45).

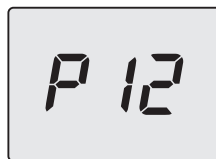

Figure 5.45

- It is possible to modify the value of parameter 12 from **01=10s** to **120=1200s** by pressing the 14 or 16 keys (each unit increase or decrease on the display corresponds to 10 seconds).
- Press button 15 (Figure 5.41) to confirm the value entered. The display will show the following (Figure 5.46) for 5 seconds, then move up to the next level.

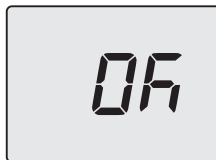

Figure 5.46

# INSTALLATION

- Press the keys 14 and 16 simultaneously (Figure 5.41) to exit the level without changing the value (return to the previous level).

To exit the parameters menu:

- wait 15 minutes without pressing any key;
- switch off the electric power supply;
- press the 14 and 16 keys simultaneously for 5 seconds (Figure 5.41) (return to previous level).

## 5.19 Selecting re-ignition frequency

When the boiler functions in normal on/off heating mode, the minimum time between two ignitions is set to 1 minute (re-ignition frequency).

This time can be changed from a minimum of 10 seconds to a maximum of 20 minutes in programming mode, using either the control panel or the remote.

- Enter “programming mode” by pressing the 14 and 16 buttons simultaneously for 5 seconds (Figure 5.47) until **HiS** (in reference to the “Boiler History” menu) appears on the LCD display (Figure 5.48).

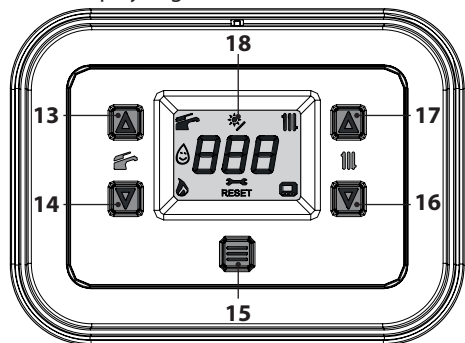

Figure 5.47

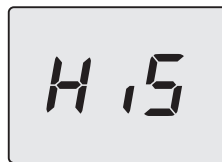

Figure 5.48

- Scroll through the menus using the 14 (back) or 16 (next) buttons until **PAr** (Figure 5.49) (in reference to the “Parameters” menu) appears on the LCD display.
- Press the 15 button for 1 second to enter the selected menu.



Figure 5.49

- Scroll through the various parameters by pressing the keys 14 (back) or 16 (forward), until **P10**, which alternates with the parameter value, appears on the LCD display (Figure 5.50).

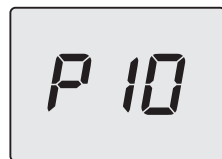

Figure 5.50

- Press the 15 button for 1 second (Figure 5.47) to open the selected parameter. The display will show the following (6=60 seconds) (Figure 5.51).

# INSTALLATION

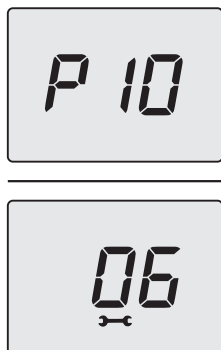

Figure 5.51

- Using keys 14 or 16, it is possible to modify the value of parameter 10 from **1=10s** to **120=1200s** (each unit on the display corresponds to an increase or decrease of 10 seconds).
- Press button 15 (Figure 5.47) to confirm the value entered. The display will show the following (Figure 5.52) for 5 seconds, then move up to the next level.

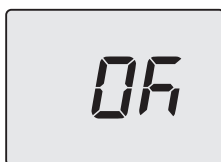

Figure 5.52

- Press the keys 14 and 16 simultaneously (Figure 5.41) to exit the level without changing the value (return to the previous level).

To exit the parameters menu:

- wait 15 minutes without pressing any key;
- switch off the electric power supply;
- press the 14 and 16 keys simultaneously for 5 seconds (Figure 5.47) (return to previous level).

## 5.20 Examples of hydraulic systems with hydraulic separator (optional)

The hydraulic separator creates a reduced load loss zone that makes the primary circuit and secondary circuit hydraulically independent. In this case, the flow rate that passes through the circuits depends exclusively on the characteristics of the flow rate of the pumps.

Therefore by using a hydraulic separator, the secondary circuit's flow rate is circulated only when the relative pump is on.

When the pump for the secondary circuit is off, there is no circulation in the corresponding circuit and therefore the flow rate pushed by the pump in the primary circuit is by-passed through the separator.

With a hydraulic separator, the production circuit can have a constant flow rate and the distribution circuit can have a variable flow rate.

## Examples of hydraulic systems

High temperature zone + low temperature zone.

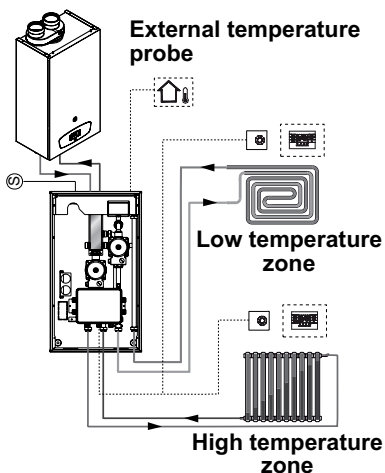

Figure 5.53

INSTALLERS

---

# INSTALLATION

---

High temperature zone + 2 low temperature zones.

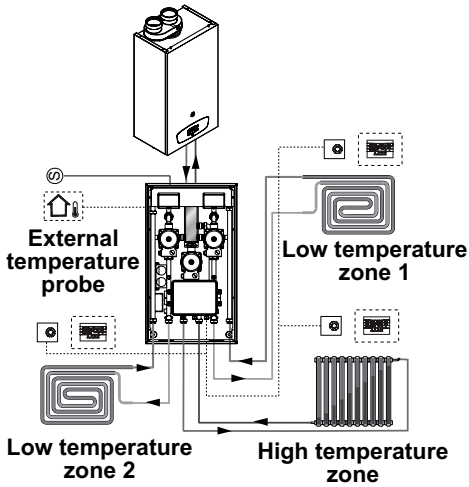

Figure 5.54

# PREPARATION FOR SERVICE

## 6 PREPARATION FOR SERVICE

### 6.1 Warnings

**Before performing the operations described below, make sure that the installed multi-way switch is in the off position.**

### 6.2 Sequence of operations

#### Gas supply

- Open the cock for the gas meter and for the boiler 8 in Figure 6.1.

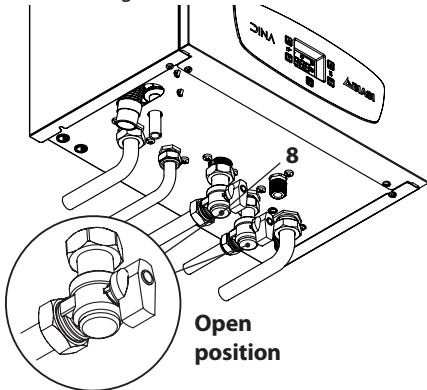

Figure 6.1

- Check for leaks in the gas fitting using a soapy solution or equivalent.
- Close the gas cock 8 in Figure 6.2.

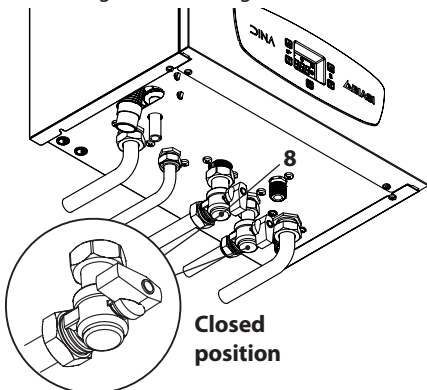

Figure 6.2

#### Filling the circuit

- Remove the front panel on the body, see section "Removing the body panels" on page 67.
- Open the installed water cocks.
- Open one or more hot water cocks to bleed the pipes.
- Loosen the automatic bleed valve cap 25 in Figure 6.3.

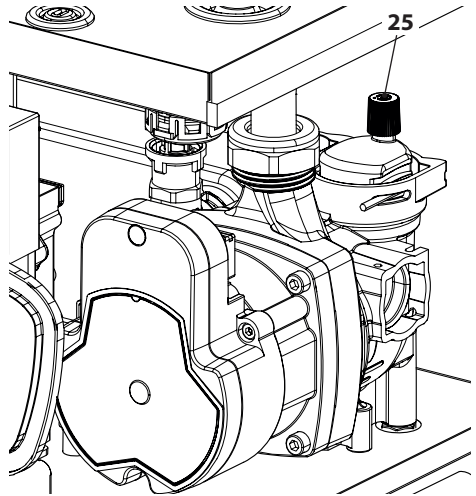

Figure 6.3

- Open the radiator cocks.
- Fill the heating circuit, see section "Filling the heating circuit" on page 16.
- Bleed the radiators and the various high points of the installation, then close any manual bleeding devices again.
- Complete filling the heating system. The installation as well as the pump must be bled multiple times.



**Fill the condensate discharge siphon with a half litre of water to prevent smoke from exiting at first ignition. The flue gas intake positioned on the flue gas outlet can be used for this operation (Figure 6.4).**

## PREPARATION FOR SERVICE

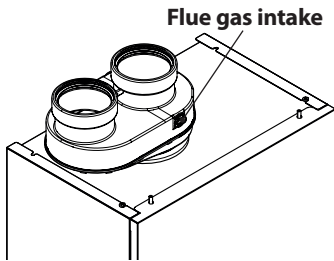

Figure 6.4



### Check pump operation/pump release

The pump electronic control circuit automatically releases the pump.

- Assemble the front panel of the body.
- Power the boiler by turning on the two-way switch fitted during installation. The LCD display shows the symbol **---** (the dashes light up in sequence to simulate a scrolling motion) (Figure 6.5).



Figure 6.5

- Press button 15 for 5 seconds until both symbols  and  appear on the display (Figure 6.6).

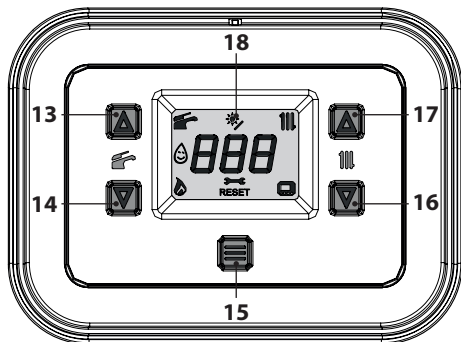

Figure 6.6



The LCD display shows the boiler temperature (primary circuit) and the symbols  and  (Figure 6.7).



Figure 6.7

- Open the gas cock.
- Make sure that the ambient thermostat is in the "heat request" position.
- Check the correct operation of the boiler, both in DHW mode and in heating mode.
- Check the gas pressures and flow rates as shown in section "CHECKING THE GAS SETTING" on page 60 of this manual.
- Check that the condensate produced during operation fills the siphon and is drained correctly in the system discharge pipe.

### Automatic air bleed function



**The Domestic Hot Water and Heating functions are not active during this period.**

- Enter "programming mode" by pressing the 14 and 16 buttons simultaneously for 5 seconds (Figure 6.6) until **HiS** (in reference to the "Boiler History" menu) appears on the LCD display (Figure 6.8).

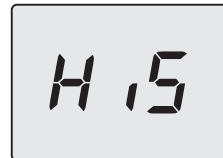

Figure 6.8

- Scroll through the various menus by pressing the keys 14 (back) or 16 (forward) until **APU** (Automatic air bleed function) appears on the LCD display (Figure 6.9).

---

## PREPARATION FOR SERVICE

---



Figure 6.9

- Press the 15 button (Figure 6.6) to activate the function. The display will show the following (Figure 6.10 and Figure 6.11).



Figure 6.10



Figure 6.11

- At the end of the procedure the display will show the following (Figure 6.12).

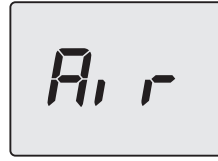

Figure 6.12

To exit the parameters menu:

- wait 15 minutes without pressing any key;
- switch off the electric power supply;
- press the 14 and 16 keys simultaneously for 5 seconds (Figure 6.6) (return to previous level).
- Turn off the boiler by pressing button 15 (Figure 6.6) for 5 seconds until the symbol **- - -** appears on the display (the dashes light up in sequence to simulate a scrolling motion) (Figure 6.5).
- Show the user how to use the appliance correctly and also explain:
  - ignition;
  - shut off;
  - making adjustments.

**The user is responsible for keeping the documentation together and intact, and within reach for consultation.**

# CHECKING THE GAS SETTINGS

## 7 CHECKING THE GAS SETTING

### 7.1 Warnings



Each time after measuring the gas pressure, fully close all tapping points that were used.

After each gas adjustment, the valve adjustment components must be sealed.



**Warning:** risk of electrocution.

The boiler is live during the operations described in this section. Never touch any electrical parts.

### 7.2 Gas operations and setting

- Remove the front panel on the boiler body, see section “Removing the body panels” on page 67.

#### Checking the network pressure

- With the boiler turned off (out of service), check the supply pressure using the tapping point 27 in Figure 7.1 and compare the value read with those shown in the Gas supply pressure table in section “Technical data M375CB.2025 SM” on page 24, “Technical data M375CB.2530 SM” page 28 and “Technical data M375CB.3035 SM” page 32.
- Fully close the tapping point 27 in Figure 7.1.

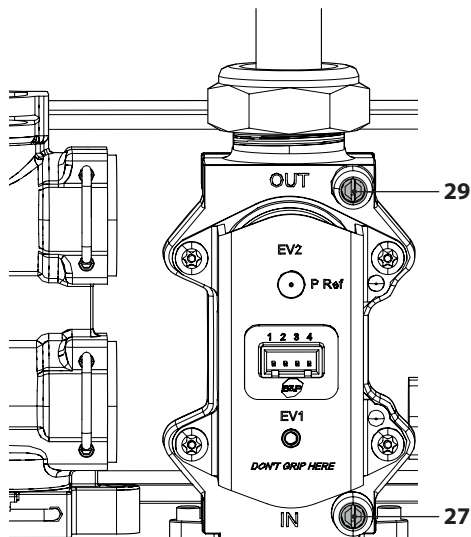

Figure 7.1

#### Check minimum burner pressure

- Connect a flue analyser to the flue gas analysis outlets on the flue gas exhaust on the boiler Figure 7.2.

#### Flue gas analysis outlets

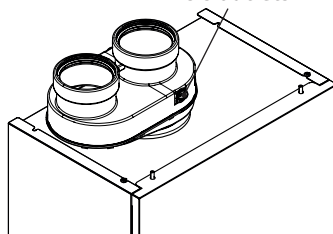

Figure 7.2

- Make sure that the room thermostat is in the “heat request” position.
- Draw off an abundant amount of DHW by opening the cocks.
- Enter “programming mode” by pressing the 14 and 16 buttons simultaneously for 5 seconds (Figure 7.3) until **HiS** (in reference to the “Boiler History” menu) appears on the LCD display (Figure 7.4).

## CHECKING THE GAS SETTINGS

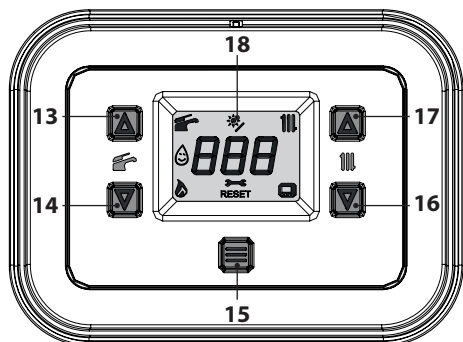

Figure 7.3

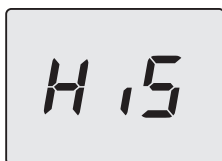

Figure 7.4

- Scroll through the various menus by pressing the keys 14 (back) or 16 (forward), until **Ch5** (Chimney sweep) appears on the LCD display (Figure 7.5).
- Press the 15 button for 1 second to enter the selected menu.



Figure 7.5

- The letters **LP**, alternating with the minimum heating water temperature (e.g. **45**), appear on the screen indicating the activation of the "chimney sweep function" at minimum power (Figure 7.6).

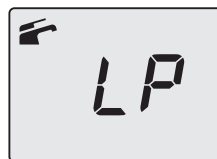

Figure 7.6

- Compare the value of **CO<sub>2</sub>** read on the flue gas analyser with the one in the "Data in DHW mode" table and the values of **CO<sub>2</sub> at Q.min.** section "Technical data M375CB.2025 SM" on page 24, "Technical data M375CB.2530 SM" page 28 and "Technical data M375CB.3035 SM" page 32.

### Check maximum burner pressure

- Press button 16 3 times until the LCD display indicates the letters **dP** (chimney sweep active in maximum DHW mode) that alternate with the value of the heating water temperature (e.g. **60**), indicating the activation of the "chimney sweep function" at maximum output in DHW mode (Figure 7.7).



Figure 7.7

- Compare the value of **CO<sub>2</sub>** read on the flue gas analyser with the **CO<sub>2</sub> value at Q.nom**

## CHECKING THE GAS SETTINGS

in DHW mode as stated in section “Technical data M375CB.2025 SM” on page 24, “Technical data M375CB.2530 SM” page 28 and “Technical data M375CB.3035 SM” page 32.

If the two values do not coincide with the value shown in section “Technical data M375CB.2025 SM” on page 24, “Technical data M375CB.2530 SM” page 28 and “Technical data M375CB.3035 SM” page 32, exit programming mode by pressing the 15 key for 5 seconds and carry out the “Automatic calibration of the gas valve” page 62.

### 7.3 Automatic calibration of the gas valve

When replacing the panel board, the fan or gas valve, or parameter **P01** on the control board is changed, the gas valve must be calibrated in order to carry out **CO<sub>2</sub>** calibration at maximum boiler output.

- Make sure that the room thermostat is in the “heat request” position.
- Draw off an abundant amount of DHW by opening the cocks.
- Enter “programming mode” by pressing the 14 and 16 buttons simultaneously for 5 seconds (Figure 7.8) until **HiS** (in reference to the “Boiler History” menu) appears on the LCD display (Figure 7.9).

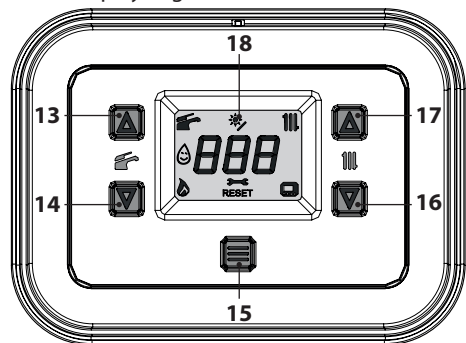

Figure 7.8

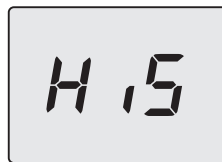

Figure 7.9

- Scroll through the menus using the 14 (back) or 16 (next) buttons until **CAF** (Figure 7.10) (in reference to the “Automatic calibration” menu) appears on the LCD display.



Figure 7.10

- Press 15 (Figure 7.8) until the message **StF** (Start Full) (Figure 7.11) appears on the LCD display.



Figure 7.11

- Allow the program to run the full process, after which **FuF** (Full Finish) will be displayed (Figure 7.12).



Figure 7.12

To exit the parameters menu:

- wait 15 minutes without pressing any key;
- switch off the electric power supply;
- press the 14 and 16 keys simultaneously for 1 seconds (Figure 7.8) (return to previous level).

---

## CHECKING THE GAS SETTINGS

---

- Check the precise gas calibration of the boiler, referring to section "Gas operations and setting" on page 60.

# GAS CONVERSION

## 8 GAS CONVERSION

### 8.1 Warnings

-  The operations to adapt the boiler to the type of gas available must be carried out by an authorised service centre.

### 8.2 Gas operations and setting

The boiler is factory set to operate with natural gas (G20).

To set boiler operation to **LPG gas (G31)**:

- Enter "programming mode" by pressing the 14 and 16 buttons simultaneously for 5 seconds (Figure 8.1) until **HiS** (in reference to the "Boiler History" menu) appears on the LCD display (Figure 8.2).

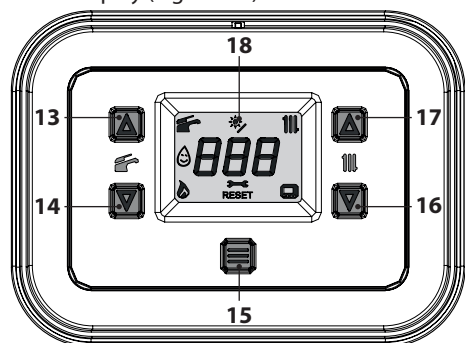

Figure 8.1

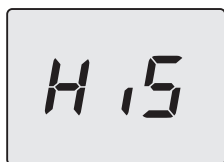

Figure 8.2

- Scroll through the menus using the 14 (back) or 16 (next) buttons until **PAr** (Figure 8.3) (in reference to the "Parameters" menu) appears on the LCD display.
- Press the 15 button for 1 second to enter the selected menu.



Figure 8.3

- Scroll through the various parameters by pressing the keys 14 (back) or 16 (forward), until **P02** (Gas type selection), which alternates with the parameter value, appears on the LCD display (Figure 8.4).



Figure 8.4

- Press the 15 button for 1 second (Figure 8.1) to open the selected parameter. The display will show the following (Figure 8.5).



Figure 8.5

- The value of parameter 02 can be changed from **00=G20** to **01=G31**, which is compatible with LPG, using the 14 or 16 keys (Figure 8.6).

---

## GAS CONVERSION

---



Figure 8.6

- Press button 15 (Figure 8.1) to confirm the value entered. The display will show the following (Figure 8.7) for 5 seconds, then move up to the next level.



Figure 8.7

- By pressing the keys 14 and 16 simultaneously (Figure 8.1) exits the level without changing the value (return to the previous level Figure 8.4).
- Scroll through the menus using the 14 (back) or 16 (next) buttons until **CAF** (Figure 8.8) (in reference to the “Automatic calibration” menu) appears on the LCD display.



Figure 8.8

For calibration, see section “Automatic calibration of the gas valve” on page 62.

To exit the parameters menu:

- wait 15 minutes without pressing any key;
- switch off the electric power supply;
- press the 14 and 16 keys simultaneously for 5 seconds (Figure 8.1) (return to previous level).
- Apply the label indicating the type of gas and the pressure value for which the unit is set. The self-adhesive label is contained in the documentation envelope attached to the boiler.

# MAINTENANCE

## 9 MAINTENANCE

### 9.1 Warnings



Protective gloves must be worn.



Cool down the appliance by shutting off the gas valve and drawing off a large quantity of water by opening the system's DHW cocks.



The operations described in this section must only be performed by professionally qualified personnel, therefore you are advised to contact an authorised service centre.

For efficient and continuous boiler operation, the user must have maintenance and cleaning carried out once a year by an authorised service centre technician. If these operations are not carried out, damage to components and boiler operation problems will not be covered by the standard warranty.

Before performing any cleaning or maintenance operation or before opening or removing the boiler panels, **isolate the unit from the electric power supply** using the multiway switch installed in the system and **close the gas valve**.

### 9.2 Programming the maintenance period

- Enter "programming mode" by pressing the 14 and 16 buttons simultaneously for 5 seconds (Figure 9.1) until **HiS** (in reference to the "Boiler History" menu) appears on the LCD display (Figure 9.2).

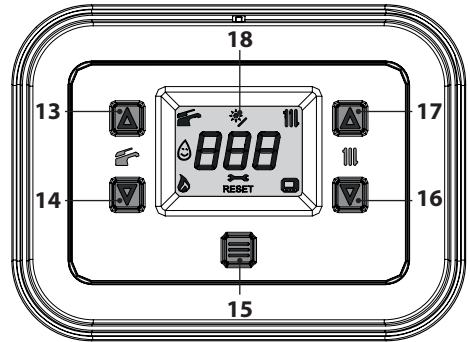

Figure 9.1



Figure 9.2

- Scroll through the menu using the 14 (back) or 16 (next) buttons until **PAr** (Figure 9.3) (in reference to the "Parameters" menu) appears on the LCD display.
- Press the 15 button for 1 second to enter the selected menu.



Figure 9.3

- Scroll through the various parameters by pressing the keys 14 (back) or 16 (forward), until **P34**, which alternates with the parameter value, appears on the LCD display (Figure 9.4).

# MAINTENANCE



Figure 9.4

- Press the 15 button for 1 second (Figure 5.47) to open the selected parameter. The display will show the following (Figure 9.5).



Figure 9.5

- The value of parameter 34 can be changed from **00** to **48** months, using the 14 or 16 keys. It is possible to set parameter 34 to **99** thereby disabling the maintenance request (symbol  will disappear from the display).
- Press button 15 (Figure 9.1) to confirm the value entered. The display will show the following (Figure 9.6) for 5 seconds, then move up to the next level.



Figure 9.6

To exit the parameters menu:

- wait 15 minutes without pressing any key;
- switch off the electric power supply;
- press the 14 and 16 keys simultaneously for 5 seconds (Figure 9.1) (return to previous level).

## 9.3 Removing the body panels

### Front panel

- Unscrew the screws **A** and remove the front panel **D** by pulling it towards you and then pushing it upwards in order to free it from the upper seats (Figure 9.7 and Figure 9.8).

### Side panels

Loosen the screws **B**, **C**, **G** and **H** in Figure 9.7 and remove the two side panels **E** and **F** push them outwards.

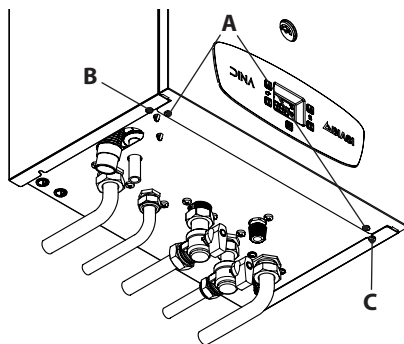

Figure 9.7

# MAINTENANCE

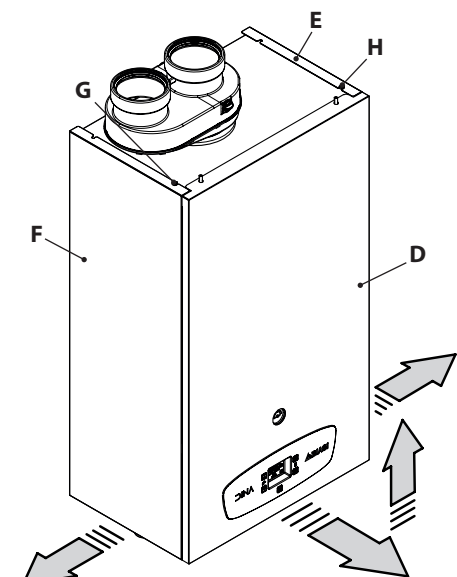

Figure 9.8

## Control panel

Remove screws I and turn the control panel J, as shown in figure Figure 9.9, for optimal access to the internal components of the boiler.

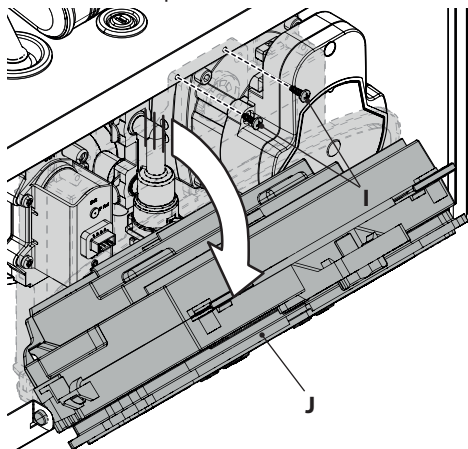

Figure 9.9

## 9.4 Reinstalling the body panels

### Side panels

Reinstall the side panels E and F following the operations described in section "Removing the body panels" on page 67 in reverse order.

### Front panel

Reinstall the front panels D working in the reverse order to that described in section "Removing the body panels" on page 67.

## 9.5 Emptying the DHW circuit

- Close the installed DHW inlet cocks.
- Open the system's DHW cocks.

## 9.6 Emptying the heating circuit

- Close the installed heating system delivery and return cocks.
- Loosen the heating circuit drain cock 11 indicated in Figure 9.10.

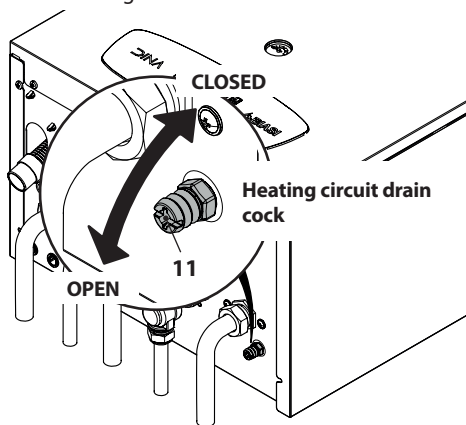

Figure 9.10

- To make draining easier, unscrew the automatic bleed valve cap 25 in Figure 9.11.

# MAINTENANCE

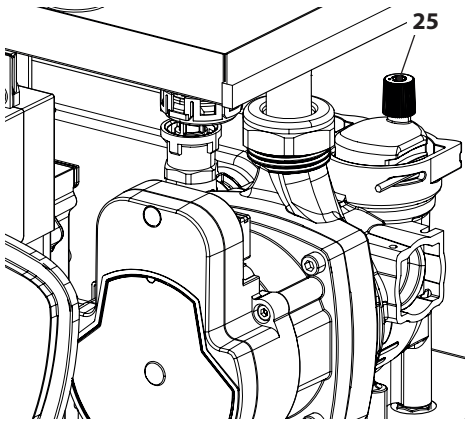

Figure 9.11

## 9.7 Cleaning the primary condensate exchanger and the burner

Removing the burner fan unit 38 in Figure 9.12.

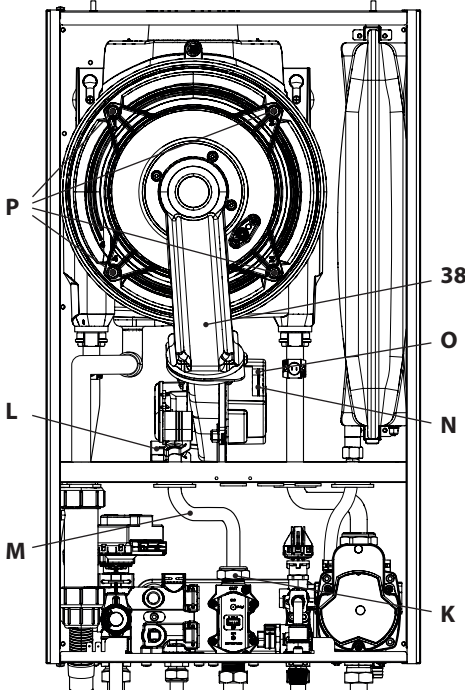

Figure 9.12

- Remove the front panel of the body and turn the control panel (see "Removing the body panels" on page 67).
- Disconnect the wiring of the ignition and detection electrodes.
- Unscrew the gas swivel joint **K**, remove the clip **L** and then remove the pipe **M**.
- Disconnect the connector **N** by pulling it downwards (Figure 9.12).
- Disconnect the fan connector **O** by pulling it downwards (Figure 9.12).
- Loosen the nuts **P** and remove the fan burner unit 38 (Figure 9.12)
- Extract the burner casing by pulling it outwards.
- The silicon gasket on the front panel of the combustion chamber Figure 9.14 must be changed if it becomes worn.

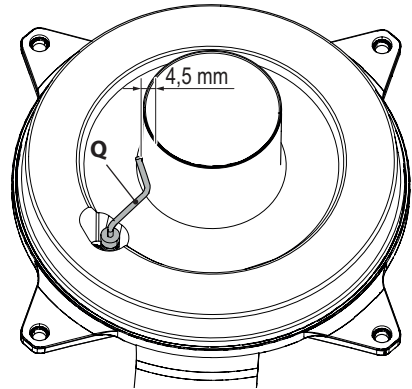

Figure 9.13

- The ignition/detection electrode **Q** in Figure 9.13 also serves as a sensor for correctly draining the condensate.
- If this electrode comes into contact with the condensate water in the combustion chamber, the boiler goes into safety lockout. Replace the insulation where wet or worn.

**Remove any build-up from the ignition/detection electrode, or replace it if worn/damaged. In any case, it must be replaced every 2 years.**

## MAINTENANCE

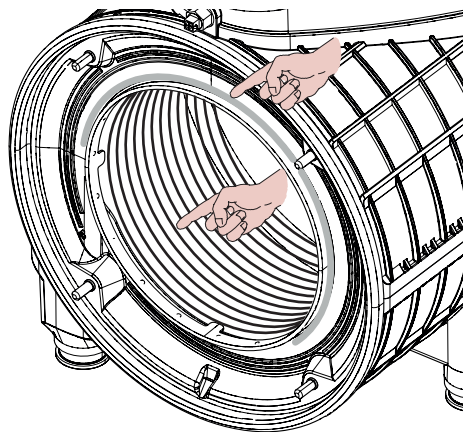

Figure 9.14

If there is any dirt on parts of the primary condensate exchanger (which can be seen after removing the burner casing), brush them with a bristle brush and then remove the dirt using a vacuum cleaner.

The burner does not require any particular maintenance. Remove any dust using a bristle brush. More specific maintenance will be assessed and performed by a technician from an Authorised Service Centre.



**For reassembly, repeat the operations in reverse order, being careful not to damage the gas pipe OR gasket when the pipe is inserted in the gas/air diaphragm. Carry out the gas tightness test after tightening the gas pipe swivel joint.**

### 9.8 Check the pressure in the heating expansion tank

Empty the heating circuit as described in section "Emptying the heating circuit" on page 68 and check that the expansion tank pressure is not less than 1 bar.

If the pressure is lower, correct the pressure.

### 9.9 Cleaning the domestic hot water exchanger

Descaling the domestic hot water exchanger will be assessed by a technician from an Authorised Service Centre, who will perform the cleaning using specific products.

### 9.10 Checking the flue gas expulsion duct

Have a technician from an authorised service centre periodically check the condition of the flue gas exhaust duct, the air duct and the efficiency of the flue gas safety circuit (at least once a year).

### 9.11 Checking boiler efficiency

Run performance checks as often as is required by the regulations in force.

- Connect a flue analyser to the flue gas analysis outlets on the flue gas exhaust on the boiler Figure 9.15.

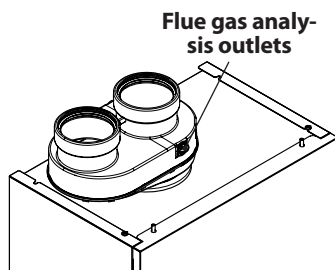

Figure 9.15

- Make sure that the room thermostat is in the "heat request" position.
- Draw off an abundant amount of DHW by opening the cocks.
- Activate the "chimney sweep function" at maximum output in heating mode (see "Setting the boiler's chimney sweep function" on page 71)
- Check the boiler combustion using the outlets located on the flue pipes (Figure 9.15) and compare the data measured with the following.

# MAINTENANCE

| Model M375CB.2025 SM                 |     |           |
|--------------------------------------|-----|-----------|
| Nominal heat input                   | kW  | 21,0      |
| Nominal efficiency                   | %   | 98,6      |
| Combustion efficiency                | %   | 98,9      |
| Air index                            | n   | 1,3       |
| Composition of CO <sub>2</sub> fumes | %   | 8,5 - 9,5 |
| Composition of O <sub>2</sub> fumes  | %   | 4,2 ÷ 6,6 |
| Composition of CO fumes              | ppm | 170       |
| Flue gas temperature                 | °C  | 76        |

Values refer to tests with 80 mm 1 + 1 m twin pipe discharge and Methane gas G20 and with heating delivery/return temperature of 60°/80°C

Figure 9.16

| Model M375CB.2530 SM                 |     |           |
|--------------------------------------|-----|-----------|
| Nominal heat input                   | kW  | 26,0      |
| Nominal efficiency                   | %   | 98,7      |
| Combustion efficiency                | %   | 98,9      |
| Air index                            | n   | 1,3       |
| Composition of CO <sub>2</sub> fumes | %   | 8,5 - 9,5 |
| Composition of O <sub>2</sub> fumes  | %   | 4,2 ÷ 6,6 |
| Composition of CO fumes              | ppm | 170       |
| Flue gas temperature                 | °C  | 78        |

Values refer to tests with 80 mm 1 + 1 m twin pipe discharge and Methane gas G20 and with heating delivery/return temperature of 60°/80°C

Figure 9.17

| Model M375CB.3035 SM                 |     |           |
|--------------------------------------|-----|-----------|
| Nominal heat input                   | kW  | 31,0      |
| Nominal efficiency                   | %   | 98,3      |
| Combustion efficiency                | %   | 98,5      |
| Air index                            | n   | 1,3       |
| Composition of CO <sub>2</sub> fumes | %   | 8,5 - 9,5 |
| Composition of O <sub>2</sub> fumes  | %   | 4,2 ÷ 6,6 |
| Composition of CO fumes              | ppm | 190       |
| Flue gas temperature                 | °C  | 80        |

Values refer to tests with 80 mm 1 + 1 m twin pipe discharge and Methane gas G20 and with heating delivery/return temperature of 60°/80°C

Figure 9.18

## 9.12 Checking the condensate discharge siphon

The condensate discharge siphon 32 (Figure 9.19) does not require any particular maintenance. Check:

- That solid deposits have not formed and remove them if necessary.
- That the condensate outlet pipes are not obstructed.

Unscrew the cap to clean inside the siphon.

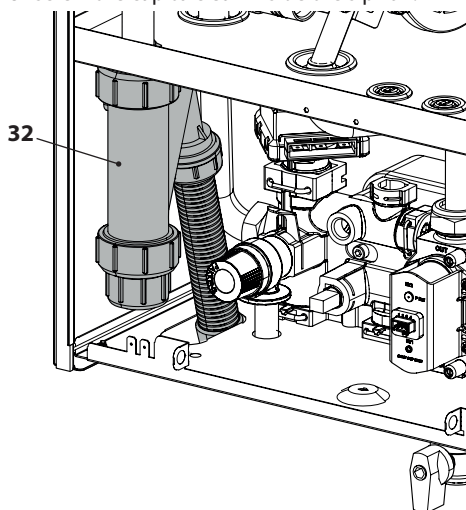

Figure 9.19

## 9.13 Setting the boiler's chimney sweep function

With the boiler set to chimney sweep mode, some automatic boiler functions can be disabled, which makes checking and monitoring easier.

- Enter "programming mode" by pressing the 14 and 16 buttons simultaneously for 5 seconds (Figure 9.20) until **HiS** (in reference to the "Boiler History" menu) appears on the LCD display (Figure 9.21).

# MAINTENANCE

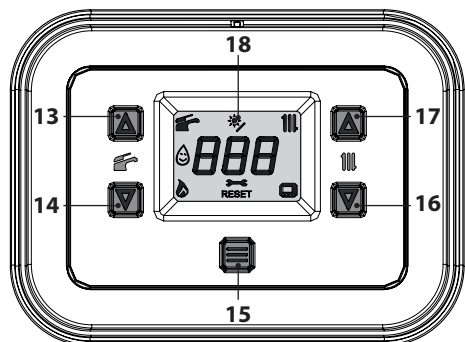

Figure 9.20

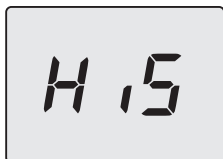

Figure 9.21

- Scroll through the various menus by pressing the keys 14 (back) or 16 (forward), until **ChS** (Chimney sweep) appears on the LCD display (Figure 9.22).
- Press the 15 button for 1 second to enter the selected menu.

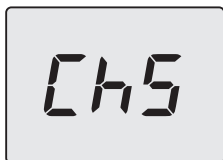

Figure 9.22

## Chimney sweep function at minimum output in domestic hot water mode

- Scroll through the various parameters by pressing the keys 14 (back) or 16 (forward) until **LP**, which alternates with the minimum heating water temperature (e.g. **45**), appears on the LCD display indicating the activation of the "chimney sweep function" at minimum power (Figure 9.23).

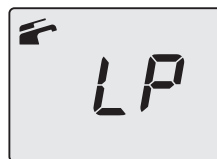

Figure 9.23

## Chimney sweep function at minimum output in heating mode

- Press button 16 (Figure 9.20) to vary the output in chimney sweep mode: when the LCD displays the letters **hP** that alternate with the temperature of the heating water (e.g. **32**), the "chimney sweep function" is at maximum output in heating mode (Figure 9.24).

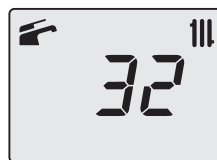

Figure 9.24

## Chimney sweep function at maximum output in heating mode

- Press button 16 (Figure 9.20) to vary the output in chimney sweep mode: when the LCD displays the letters **cP** that alternate with the temperature of the heating water (e.g. **60**), the "chimney sweep function" is at maximum output in heating mode (Figure 9.25).

# MAINTENANCE

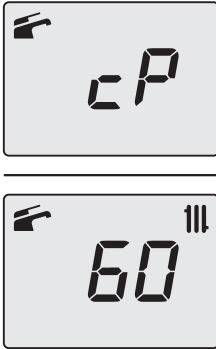

Figure 9.25

### Chimney sweep function at maximum output in domestic hot water mode

- Press button 16 (Figure 9.20) again to vary the output in chimney sweep mode: when the LCD displays the letters **dP** that alternate with the temperature of the heating water (e.g. **60**), the "chimney sweep function" is at maximum output in domestic hot water mode (Figure 9.26);

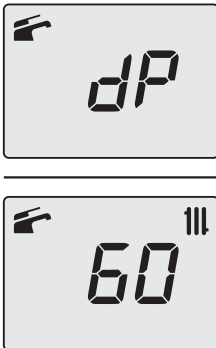

Figure 9.26

- Press keys 14 and 16 simultaneously (Figure 9.20) for 1 second to exit "chimney sweep mode" and return to the menu list.

To exit the parameters menu:

- wait 15 minutes without pressing any key;
- switch off the electric power supply;
- press the 14 and 16 keys simultaneously for 5 seconds (Figure 9.20) (return to previous level).

### 9.14 Settings for changing the control board

For information on replacing and configuring the control board, please contact an authorised service centre.

**Important:** In order to check boiler operation and any change to factory-set parameters, the table in Figure 9.27 must be completed with the values that are displayed when scrolling through the control board configuration parameters.

**This makes it possible to correctly adjust the boiler if the control board is replaced.**

| PARAMETERS                                       | LCD | VALUE |
|--|-----|-------|
| Boiler model/type                                | P01 |       |
| Type of gas                                      | P02 |       |
| User interface                                   | P03 |       |
| Type of domestic hot water exchanger             | P04 |       |
| Type of primary circuit control device           | P05 |       |
| Type of DHW flow control device                  | P06 |       |
| Maximum Temperature heating delivery (°C)        | P07 |       |
| Minimum heating delivery temperature (°C)        | P08 |       |
| Maximum heating output (%)                       | P09 |       |
| Re-ignition frequency in heating mode (*10 sec.) | P10 |       |
| Adjusting the minimum pump speed (%)             | P11 |       |
| Pump post-circulation                            | P12 |       |
| Pump mode operation                              | P13 |       |
| Value of the external sensor K                   | P14 |       |
| Correct heating system pressure (*10 bar)        | P15 |       |

## MAINTENANCE

| PARAMETERS  | LCD        | VALUE |
|---|------------|-------|
| Maximum heating system pressure limit   | <b>P16</b> |       |
| ΔT heating delivery/return due to reduction of pump speed   | <b>P17</b> |       |
| Adjusting maximum domestic hot water temperature  | <b>P18</b> |       |
| Adjusting minimum temperature of domestic hot water   | <b>P19</b> |       |
| Minimum closing flow rate of the DHW flow switch (ON)   | <b>P20</b> |       |
| Minimum opening flow rate of the DHW flow switch (OFF)  | <b>P21</b> |       |
| Ignition delay in DHW mode  | <b>P22</b> |       |
| Burner shut-off as a function of DHW temperature  | <b>P23</b> |       |
| Burner ignition as a function of DHW temperature  | <b>P24</b> |       |
| DHW preheating mode ( <b>01</b> =M375V.2025 SM - M375V.2530 SM, <b>02</b> =M375V.3035 SM)           | <b>P25</b> |       |
| DHW post-heating mode (at end of DHW)   | <b>P26</b> |       |
| Adjusting output power in DHW mode (%)  | <b>P27</b> |       |
| Adjusting maximum DHW temperature in anti-legionella function (°C) (only for boilers with a sensor) | <b>P28</b> |       |
| Anti-legionella function activation frequency (days)  | <b>P29</b> |       |
| Reset (restores factory settings)   | <b>P30</b> |       |
| Chimney sweep   | <b>P31</b> |       |

| PARAMETERS  | LCD        | VALUE |
|---|------------|-------|
| Adjusting the minimum power in DHW mode (%) ( <b>09</b> =M375V.2025 SM, <b>10</b> =M375V.2530 SM, <b>13</b> =M375V.3035 SM)   | <b>P32</b> |       |
| Regulation of the minimum power in heating mode (%) ( <b>09</b> =M375V.2025 SM, <b>10</b> =M375V.2530 SM, <b>13</b> =M375V.3035 SM)   | <b>P33</b> |       |
| Maintenance intervals (months)  | <b>P34</b> |       |
| Antifreeze activation temperature   | <b>P35</b> |       |
| Antifreeze deactivation temperature   | <b>P36</b> |       |
| Antifreeze activation temperature with external sensor  | <b>P37</b> |       |
| External relay operating mode 1 ( <b>0</b> =OFF, <b>1</b> =Zone by remote, <b>2</b> =Alarm)   | <b>P38</b> |       |
| External relay operating mode 2 ( <b>0</b> =OFF /TA2=OFF, <b>1</b> =Zone heat. 2 / TA2 active, <b>2</b> = EVG ext / TA2 Active, <b>3</b> = Anomaly / TA2 Active, <b>4</b> =Remote filling / TA2 active) | <b>P39</b> |       |
| Size shown on the display during operation ( <b>0</b> =T. CH or T.DHW, <b>1</b> =onlyT.CH, <b>2</b> =only T.DHW, <b>3</b> =CH pressure, <b>4</b> =T.ext)  | <b>P40</b> |       |
| Messages display ( <b>0</b> all, <b>1</b> =boiler status and errors, <b>2</b> =boiler status only)  | <b>P41</b> |       |
| Not used  | <b>P42</b> | ----- |
| Not used  | <b>P43</b> | ----- |
| Not used  | <b>P44</b> | ----- |
| Not used  | <b>P45</b> | ----- |

# MAINTENANCE

| PARAMETERS                             | LCD | VALUE |
|--|-----|-------|
| Not used                               | P46 | ----- |
| Pump automatic air bleed               | P47 |       |
| Maximum pump speed in heating mode (%) | P48 |       |
| Maximum pump speed in DHW mode (%)     | P49 |       |
| Not used                               | P50 | ----- |
| Not used                               | P51 | ----- |
| Chimney diaphragm                      | P52 |       |
| Fan speed at maximum                   | P53 |       |
| Fan speed at minimum                   | P54 |       |
| Ignition power                         | P55 |       |
| Gas valve management                   | P56 |       |
| Type of external sensor                | P57 |       |
| Not used                               | P58 | ----- |
| Not used                               | P59 | ----- |
| Not used                               | P60 | ----- |
| Check pump flow rate                   | P61 |       |
| OFFSET flue sensor                     | P62 |       |

Figure 9.27

- Enter “programming mode” by pressing the 13 and 15 buttons simultaneously for 5 seconds (Figure 9.28) until **HiS** (in reference to the “Boiler History” menu) appears on the LCD display (Figure 9.29).

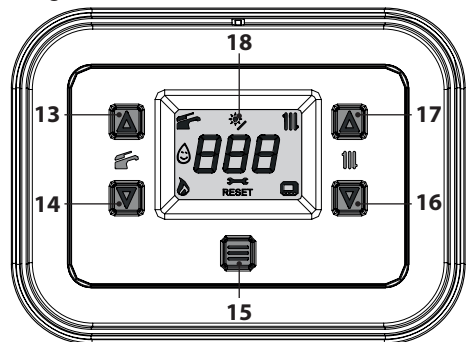

Figure 9.28



Figure 9.29

- Scroll through the menus using the 13 (back) or 15 (next) buttons until **PAr** (Figure 9.30) (in reference to the “Parameters” menu) appears on the LCD display.



Figure 9.30

- Press the 14 button for 1 second to enter the selected menu.

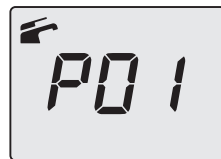
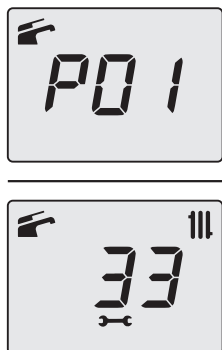

Figure 9.31

- Press the 14 button for 1 second (Figure 9.28) to open the selected parameter. The display will show the following (**31**=M375V.2025 SM, **33**=M375V.2530 SM or **34**=M375V.3035 SM) (Figure 9.32).

# MAINTENANCE



**Figure 9.32**

- By pressing the keys 13 and 15 simultaneously (Figure 9.28) exits the level without changing the value (return to the previous level Figure 9.31).
- Scroll through the various parameters using the 13 (back) or 15 (next) buttons until **P02** appears on the LCD display, alternating with the parameter value.
- Repeat the previous steps to display the value and proceed to the next parameter.
- Set the following parameters:

| PARAMETERS                             | LCD        | VALUE    |
|--|------------|----------|
| Type of gas                            | <b>P02</b> | G20 = 00 |
|  |            | G31 = 01 |
| User interface                         | <b>P03</b> | 00       |
| Type of domestic hot water exchanger   | <b>P04</b> | 00       |
| Type of primary circuit control device | <b>P05</b> | 03       |
| Type of DHW flow control device        | <b>P06</b> | 03       |
| Adjusting the minimum pump speed (%)   | <b>P11</b> | 70       |
| Pump mode operation                    | <b>P13</b> | 02       |

| PARAMETERS  | LCD        | VALUE |
|---|------------|-------|
| DHW preheating mode (M375V.2025 SM - M375V.2530 SM)                 | <b>P25</b> | 01    |
| DHW pre-heating mode (M375V.3035 SM)                                |            | 02    |
| Adjusting the minimum power in DHW mode (%) (M375V.2025 SM)         | <b>P32</b> | 09    |
| Adjusting the minimum power in DHW mode (%) (M375V.2530 SM)         |            | 10    |
| Adjusting the minimum power in DHW mode (%) (M375V.3035 SM)         |            | 13    |
| Regulation of the minimum power in heating mode (%) (M375V.2025 SM) | <b>P33</b> | 09    |
| Regulation of the minimum power in heating mode (%) (M375V.2530 SM) |            | 10    |
| Regulation of the minimum power in heating mode (%) (M375V.3035 SM) |            | 13    |
| Size shown on the display during operation                          | <b>P40</b> | 00    |
| Pump automatic air bleed  | <b>P47</b> | 01    |
| Maximum pump speed in heating mode (%)                              | <b>P48</b> | 90    |
| Maximum pump speed in DHW mode (%)                                  | <b>P49</b> | 90    |
| Check pump flow rate  | <b>P61</b> | 39    |
| OFFSET flue sensor  | <b>P62</b> | 15    |

To exit the parameters menu:

- wait 15 minutes without pressing any key;
- switch off the electric power supply;
- press the 13 and 15 keys simultaneously for 5 seconds (Figure 9.28) (return to previous level).

---

## MAINTENANCE

---

Enter the **CAF** menu (Automatic calibration) and start calibration. See paragraph "Automatic calibration of the gas valve" on page 62.

---

## BOILER DISPOSAL AND RECYCLING

---

### 10 BOILER DISPOSAL AND RECYCLING

The boiler and any accessories must be disposed of correctly, recycling the different materials where possible.

The installer must dispose of the packaging used to transport the boiler.



**Please observe the regulations currently in force regarding recycling and disposing of the boiler and any accessories.**

**For electronic appliances specifically, please see Directive 2012/19/EU and ANNEX IX of the Italian Decree transposing this Directive, DL49/14.**







17962.3827.0 Base\_EN

2424

80A5 EN

### **BSG Caldaie a Gas S.p.a.**

*Registered office, sales and administrative  
headquarters, plant and technical support*

33170 PORDENONE (Italy) – Via Pravolton, 1/b



+39 0434.238311



[www.biasi.it](http://www.biasi.it)

#### **This manual replaces previous versions.**

In order to constantly improve its products, BSG Caldaie a Gas S.p.A. reserves the right to change the data provided in this manual at any time and without notice. Product warranty pursuant to Leg. Decree. no. 24/2002